



**Encadrant :** Marc Dibeh

**Groupe 1 :** Jeanne - Annabel - Fanny - Héloïse

**Groupe 2 :** Sarah - He - Songeui - Emma - Carla - Aline - Pierre

**Groupe 3 :** Paul - Clara - Léo - Jean-Eudes - Edouard

# Workshop

**Beyrouth,**  
je vous écris  
de **Toulon**

# Workshop

**Beyrouth,**  
je vous dessine  
de **Toulon**

# Cette ville qu'on ne connaît pas

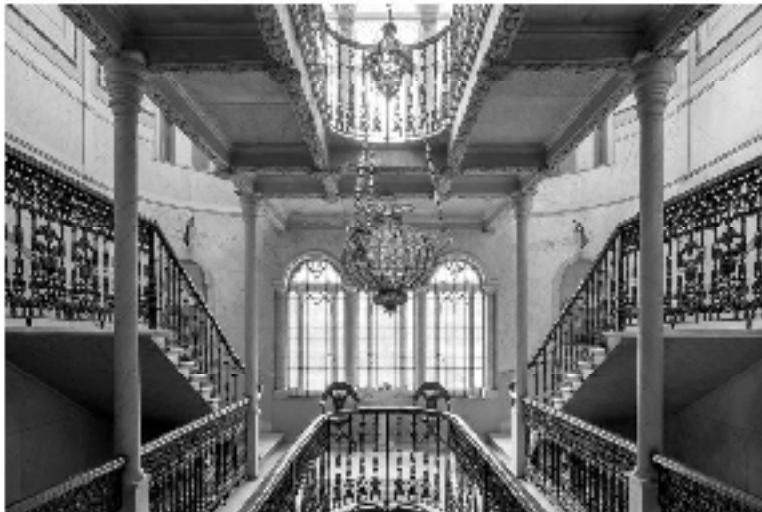

**Culturelle**

**Historique**

**Multi-générationnelle**

**Dynamique**

# Pensons ensemble

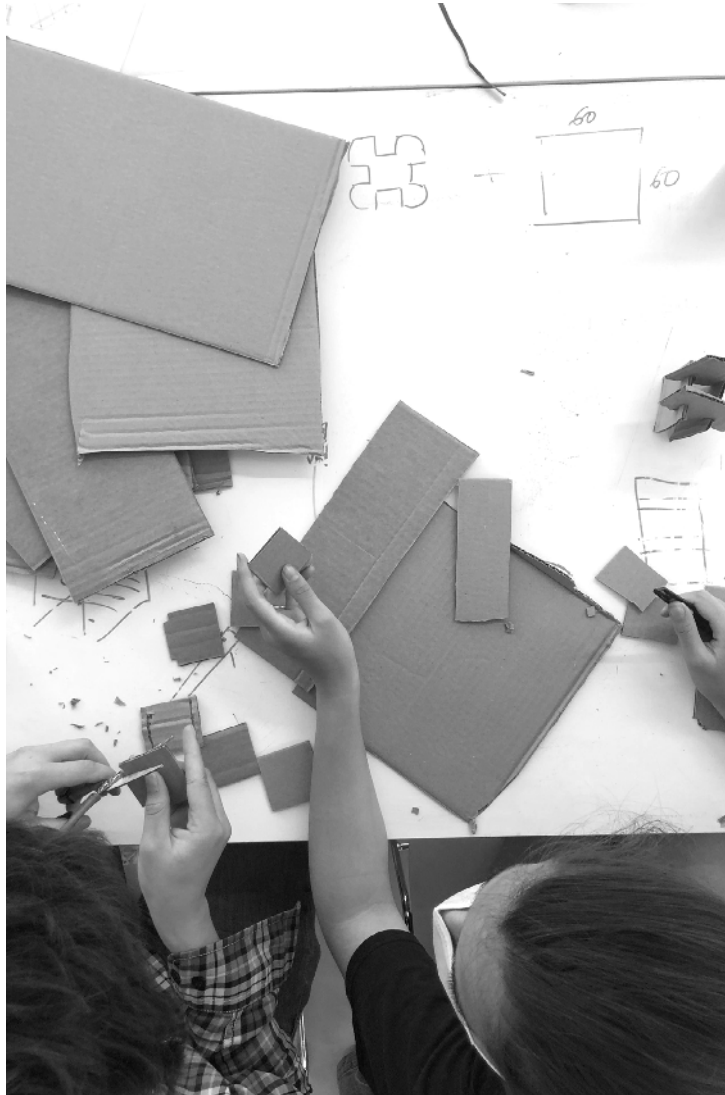

# Les héros locaux

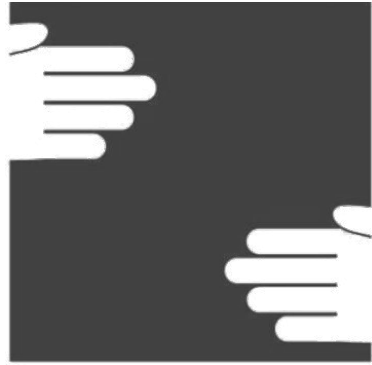

BEIT EL  
BARAKA



arcenciel.org



# Outils à disposition

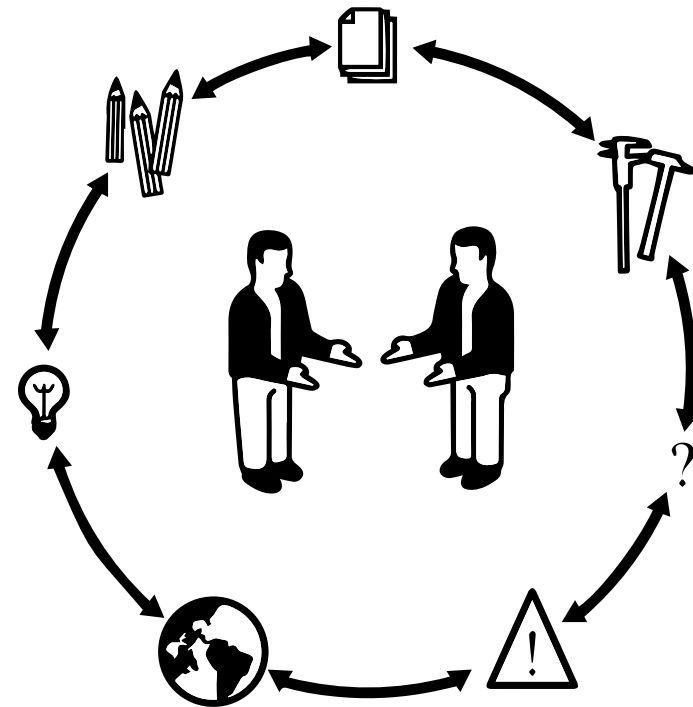





# Les collections

Beyrouth, je vous dessine de Toulon



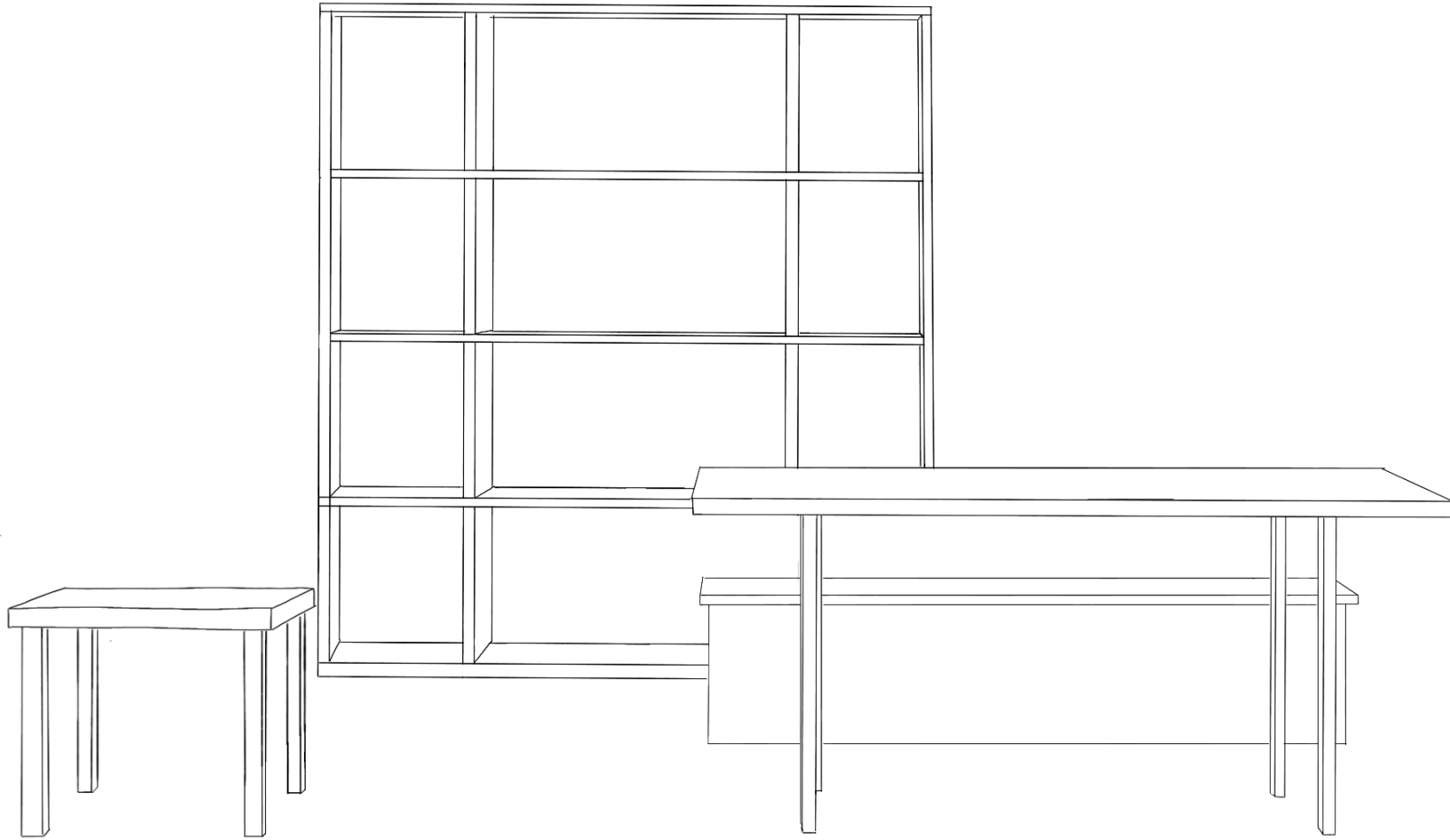

# Les collections

Beyrouth, je vous dessine de Toulon



# Sawa

Beyrouth, je vous écris de Toulon



# Intentions

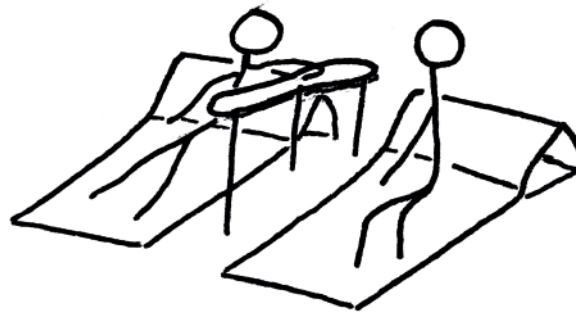

## Servir

Recevoir ses proches  
Leur apporter à boire et à manger

## S'installer au sol

Se retrouver pour discuter  
S'installer confortablement par terre

## Illuminer

Remédier au coupure de courant  
Illuminer à la bougie ou à l'électricité

# Recherches de scénarios

Recevoir chez soi sa famille, ses voisins ou ses amis.

Que faire avec ses invités ? Ou se réunir et à combien ?

Recherches de deux scénarios types autour du service du thé/café, et du jeu entre amis. Un troisième scénario illustre ce qui se passe lors d'une coupure d'électricité.

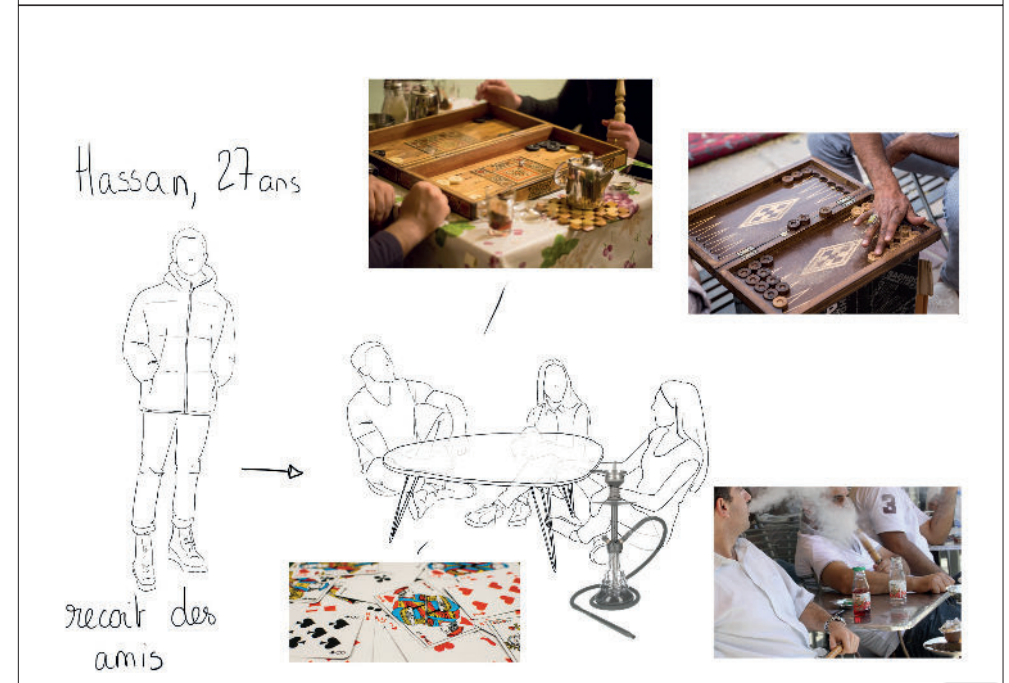
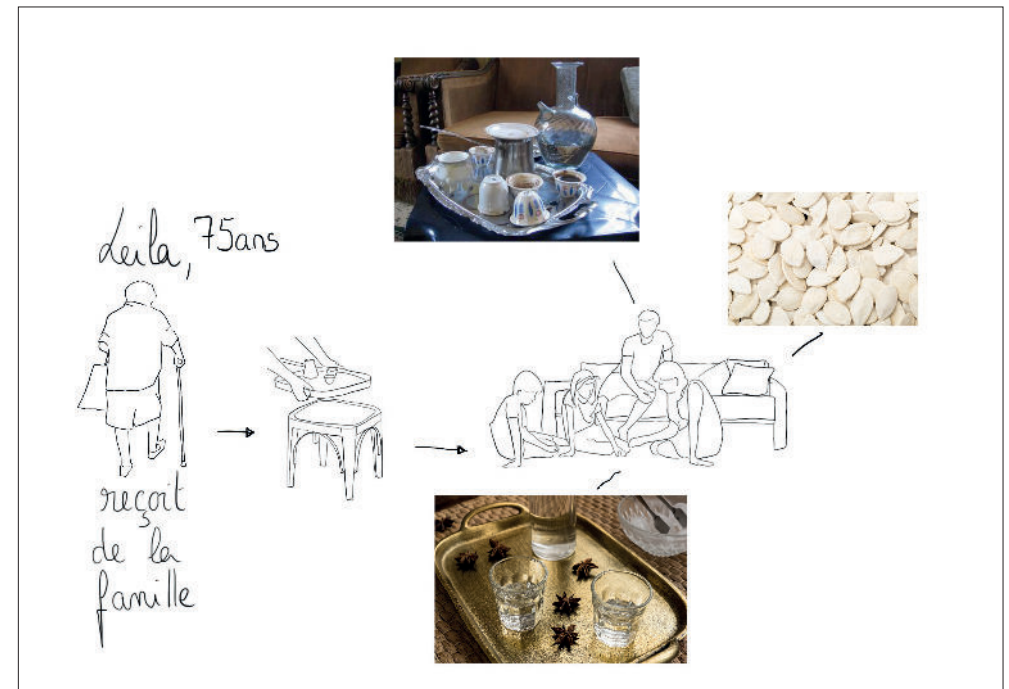
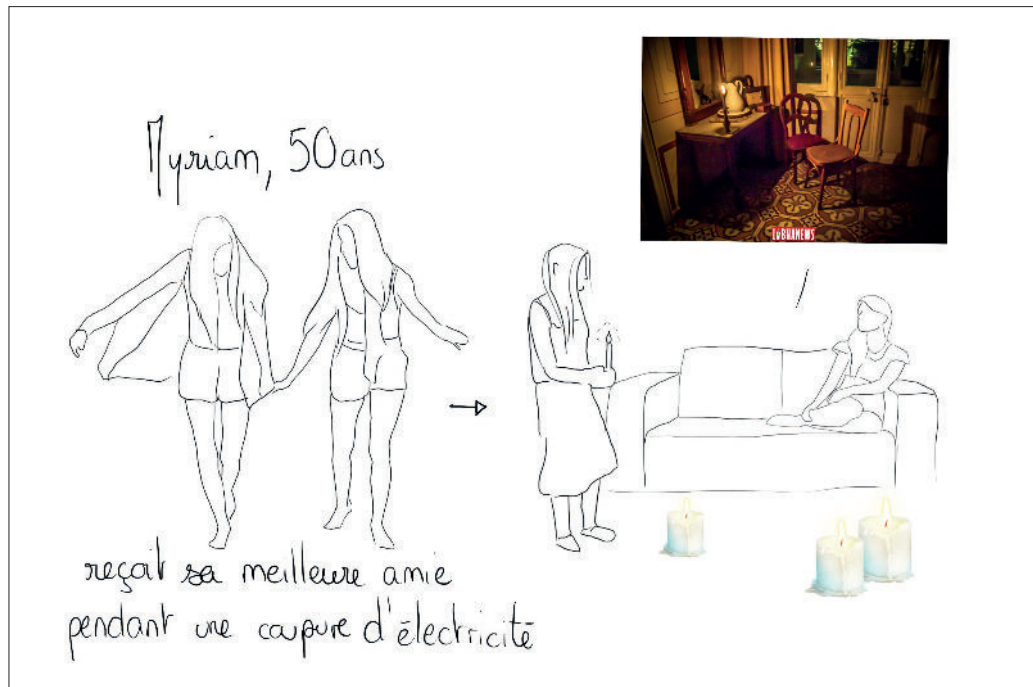

# Recherches de formes et de couleurs

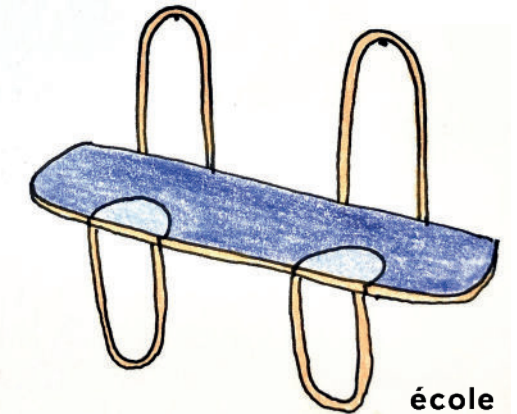
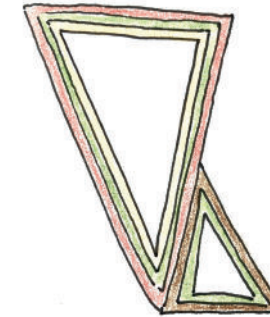
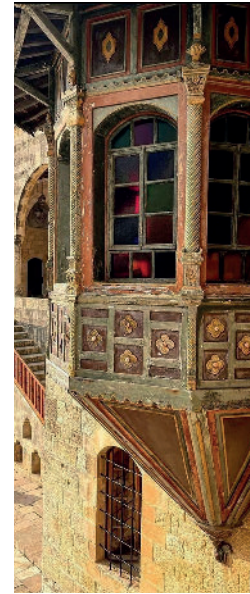
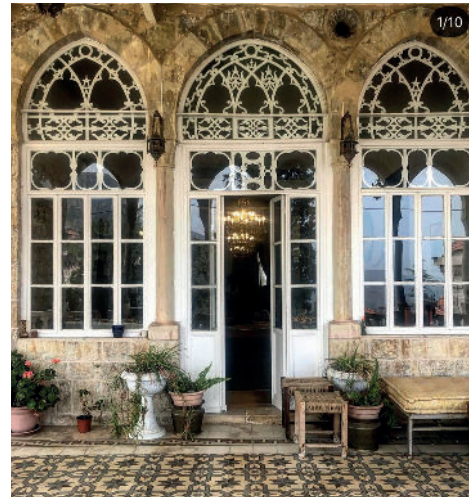
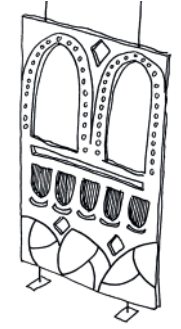
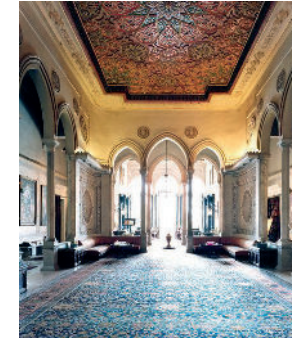
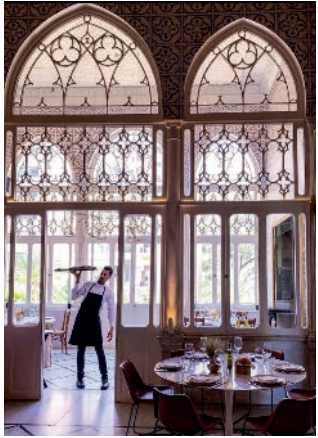

# Warm up

## La table accoudoir

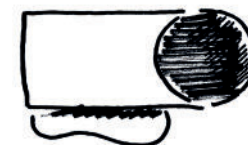
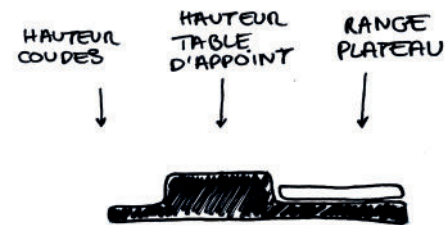
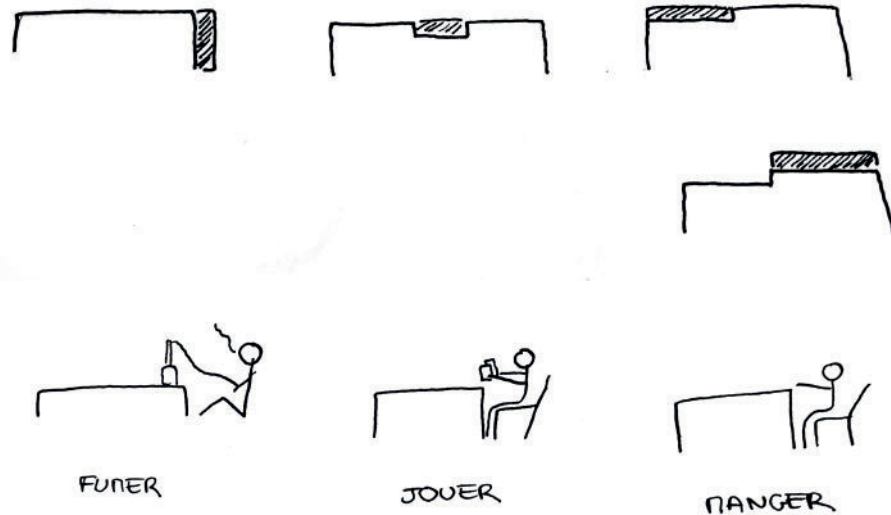
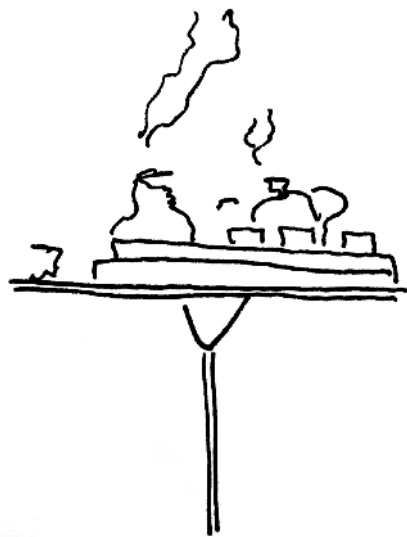
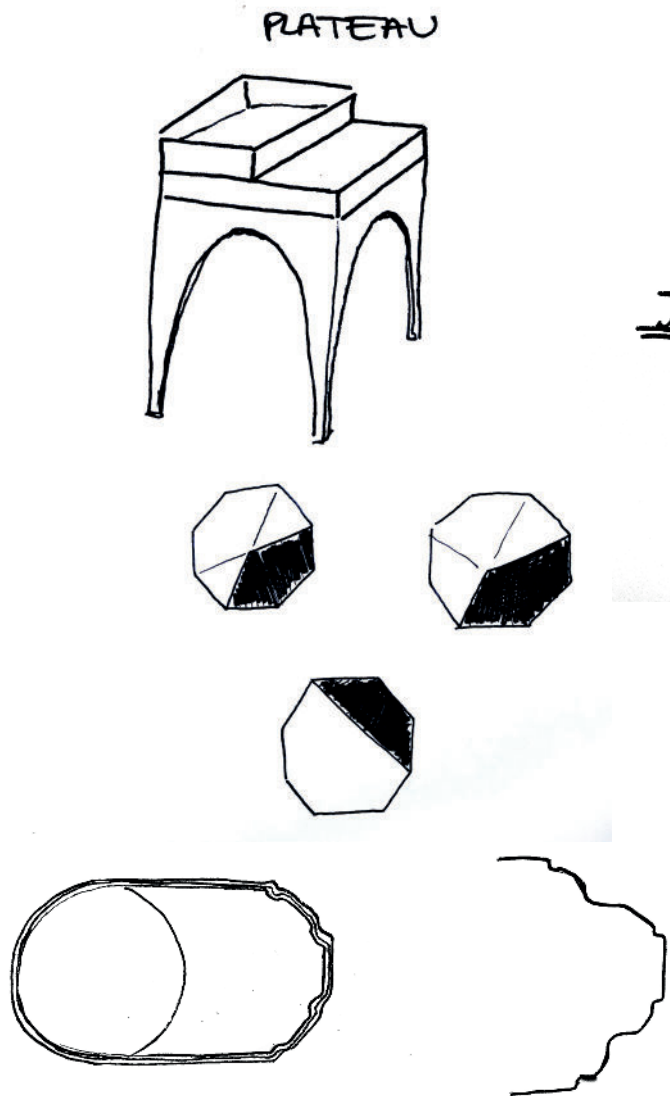

Recherches



# Scénario d'usage



1

Lynda apporte le café à son invitée à l'aide d'un plateau, et le pose sur la table.

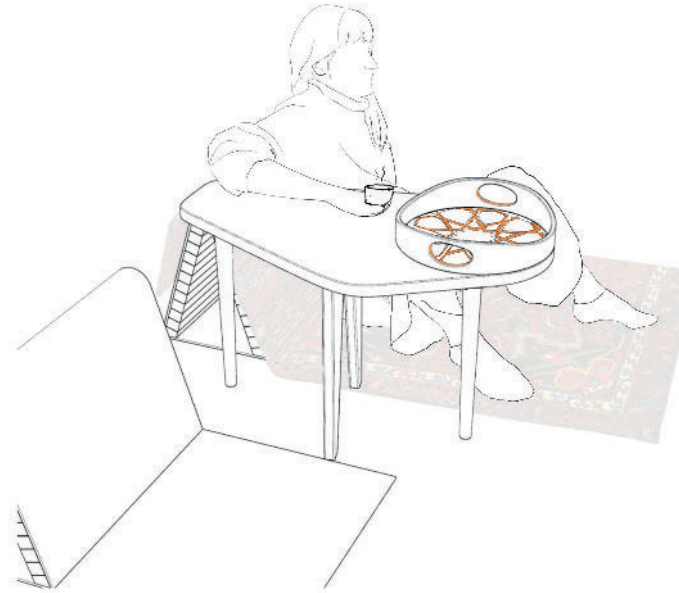

2

Elles s'accourent sur la table pour discuter et boire leurs cafés.

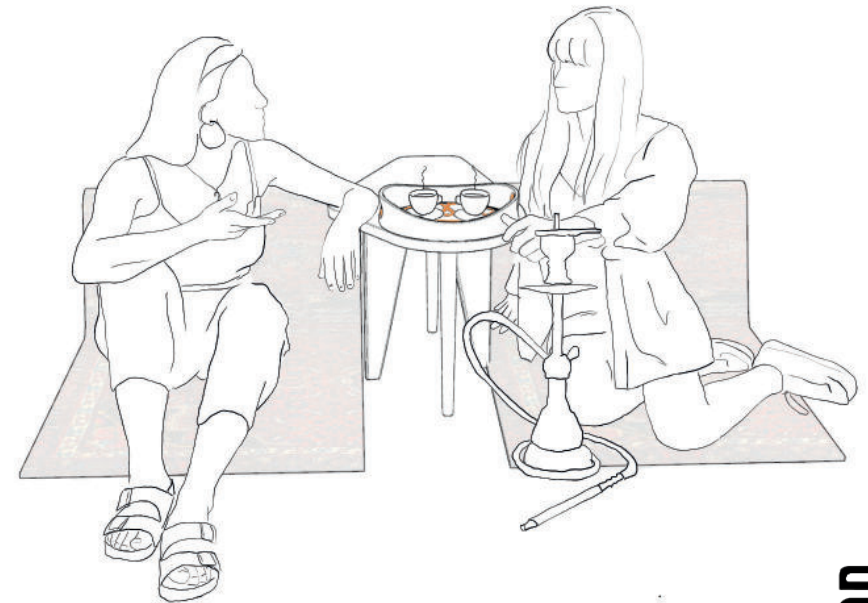

# Warm Up

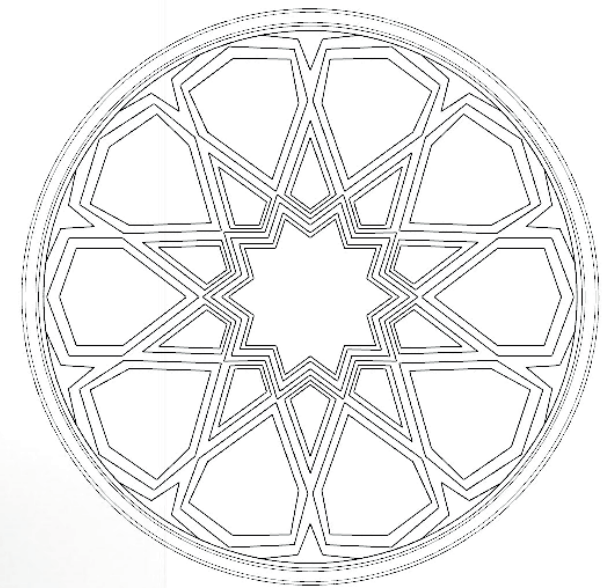

# Documents techniques

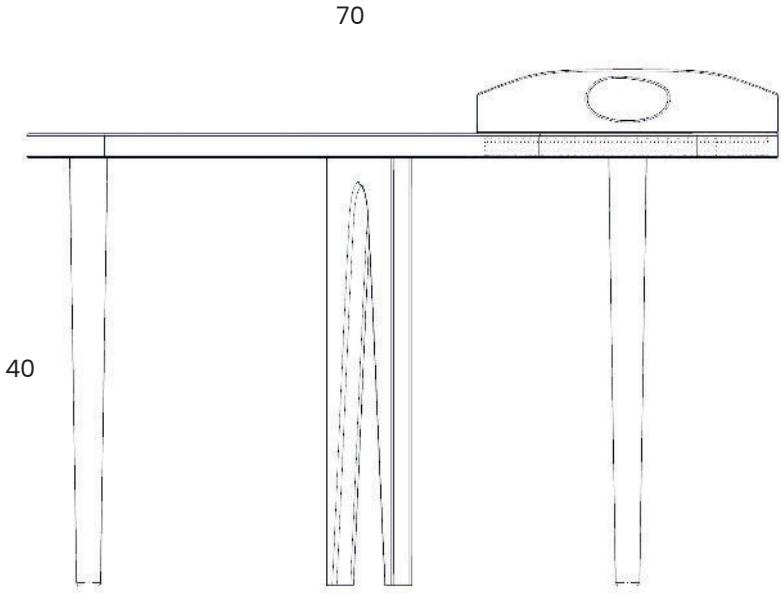

Vue de gauche

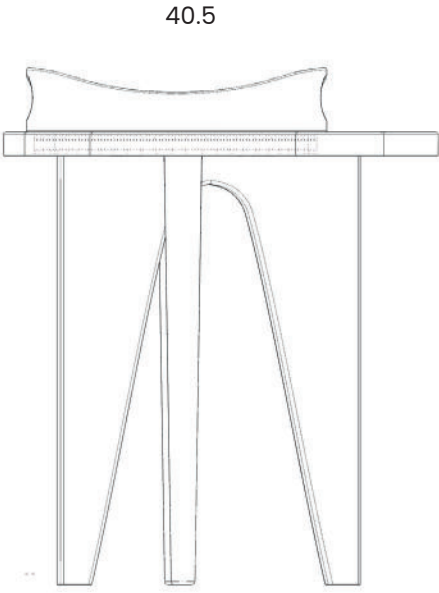

Vue de face

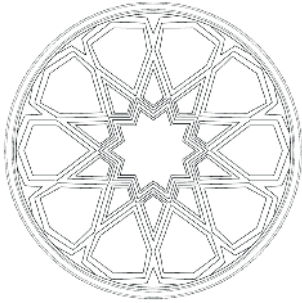

37.80

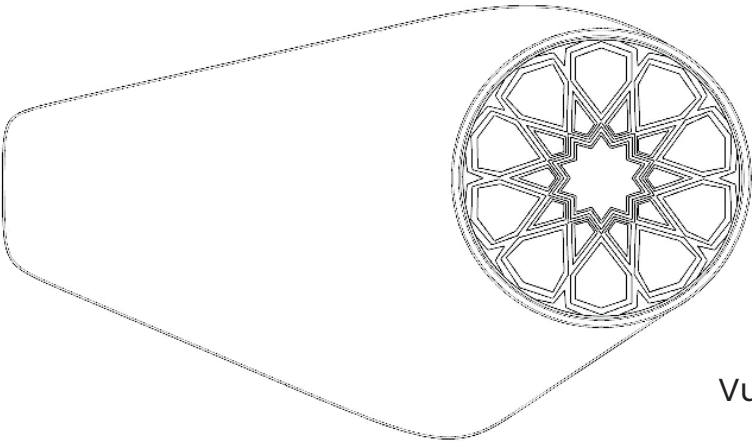
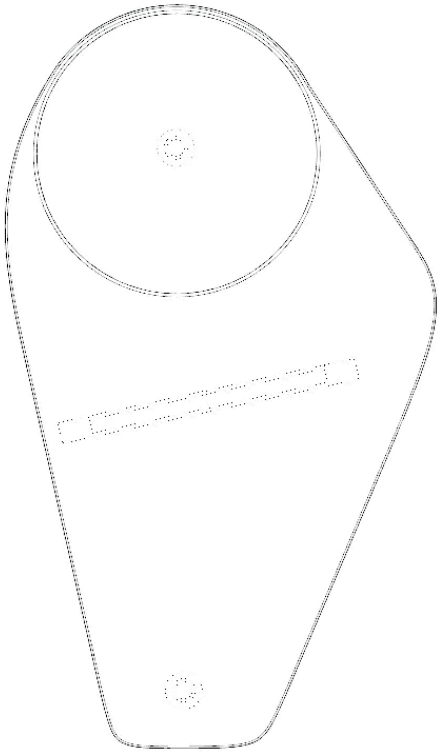

28

Vue de dessus

# Lean on

## Le dossier de sol

## Scénario d'usage

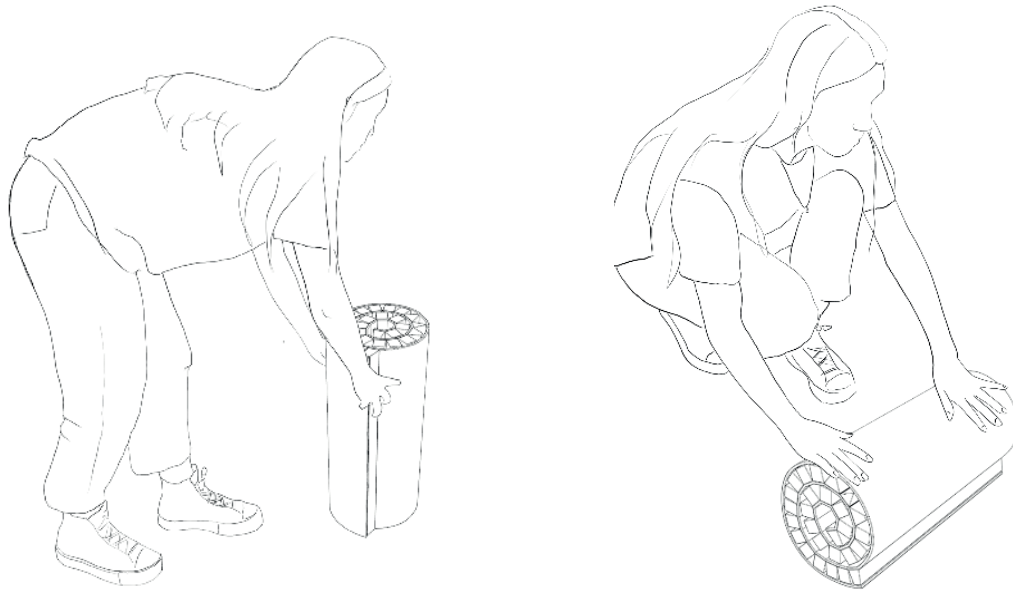

1 Lena déroule son dossier et l'étale sur le sol.

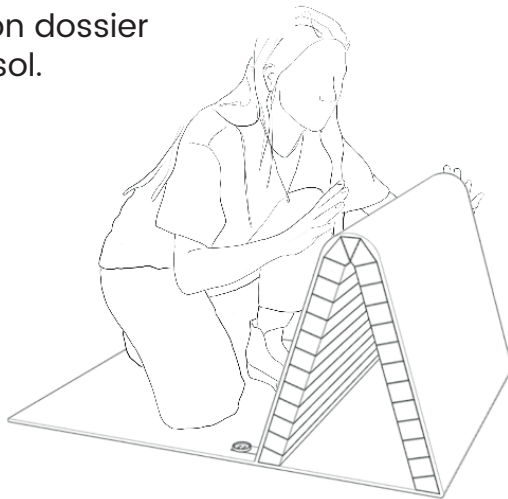

2 Elle monte le dossier et le fixe grâce aux boutons.

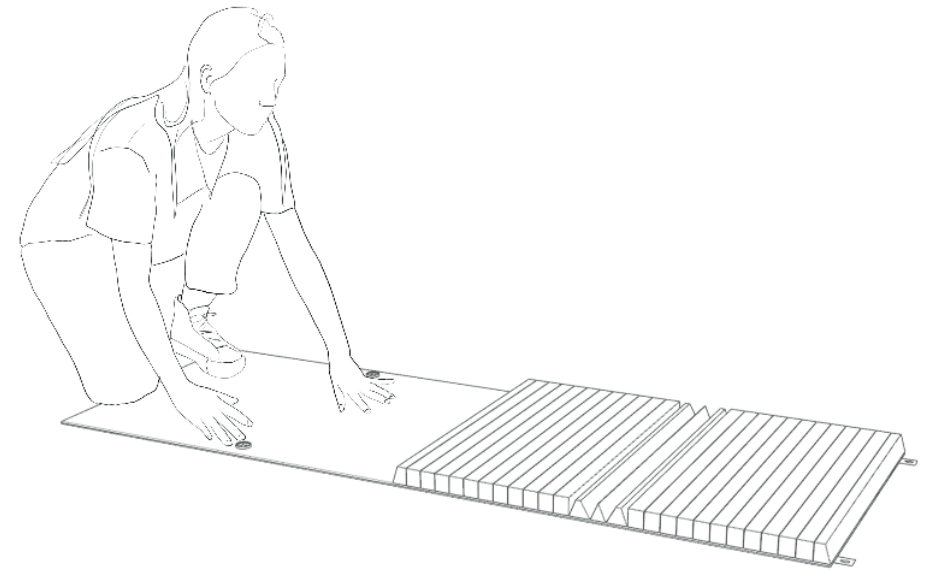

3 Lena y installe son tapis pour s'installer confortablement.

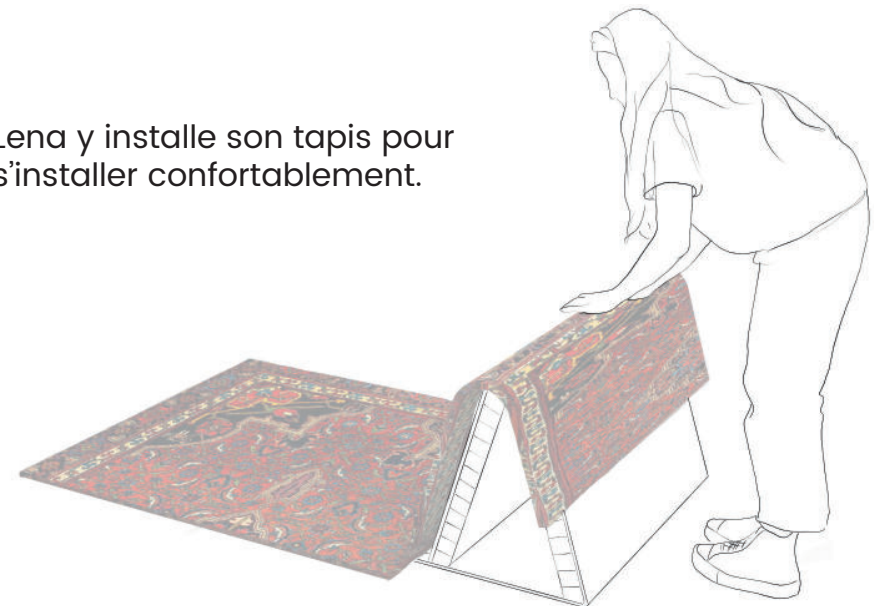

# Lean On

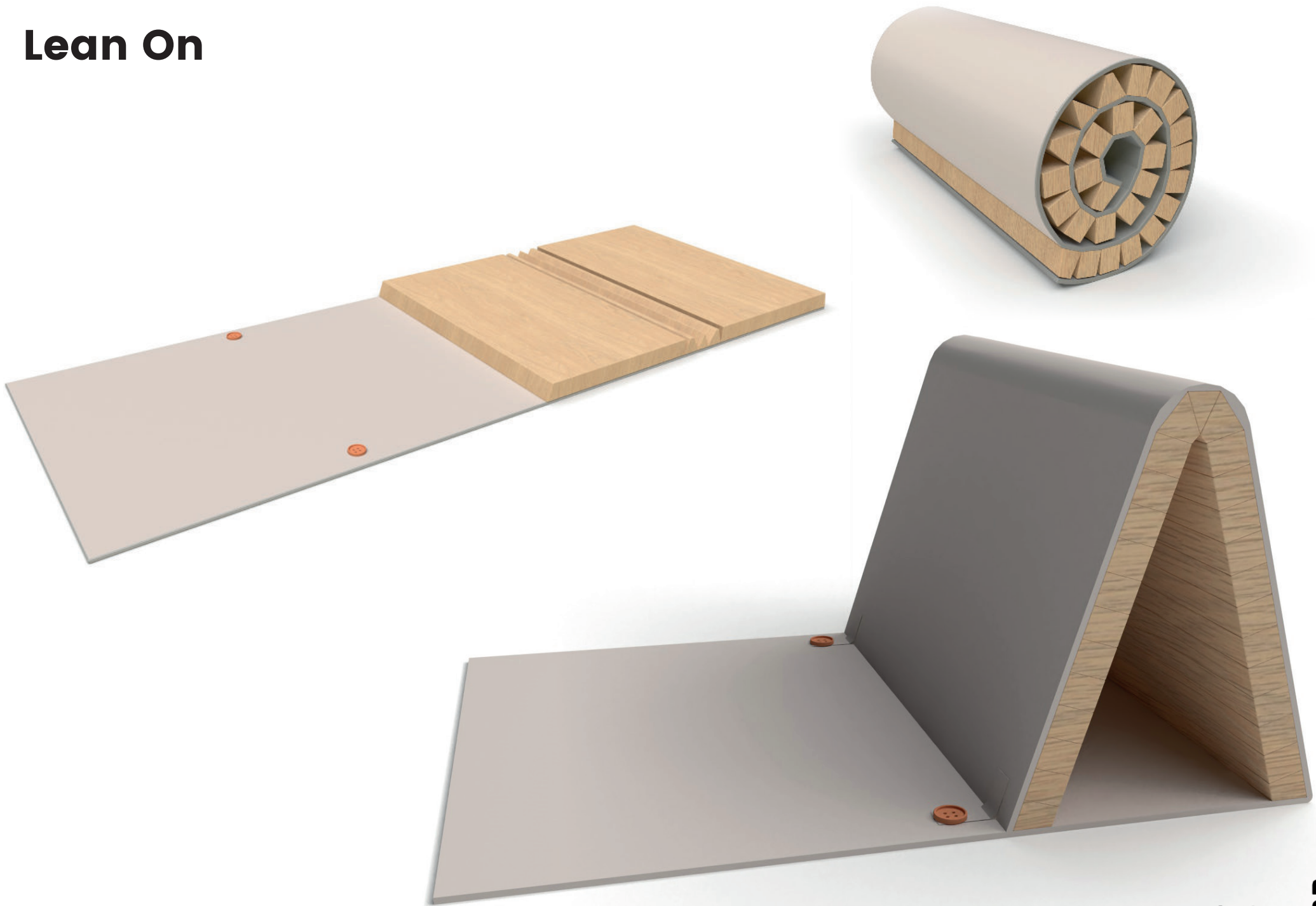

# Documents techniques

Installé

Déplié

Rangé

Vue de dessus

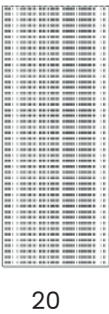
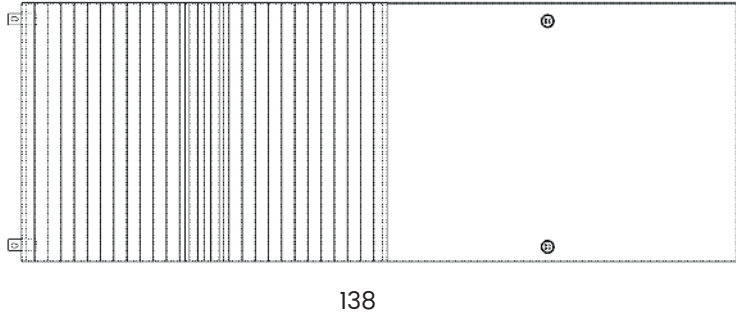
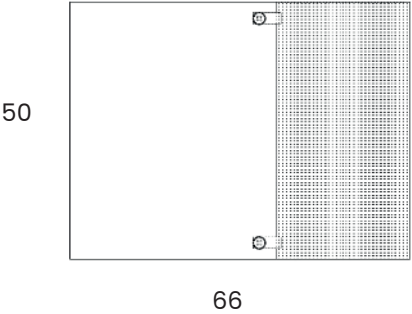

Vue de face

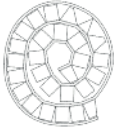
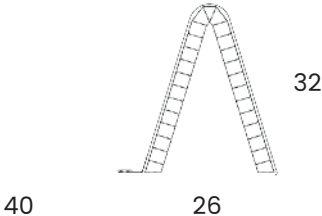

Vue de gauche

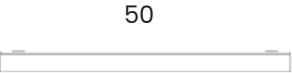

# Reflect & Diffuse

## Les luminaires

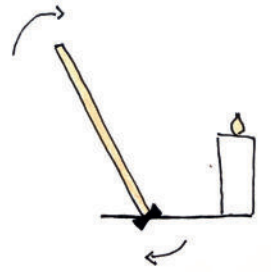
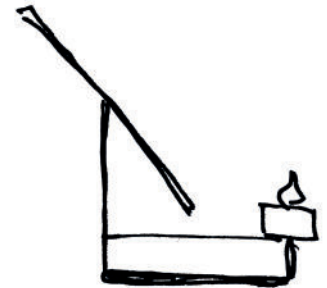
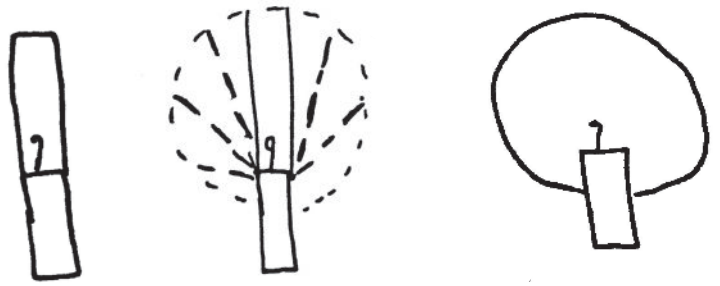
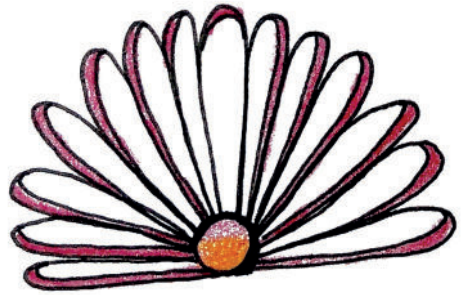
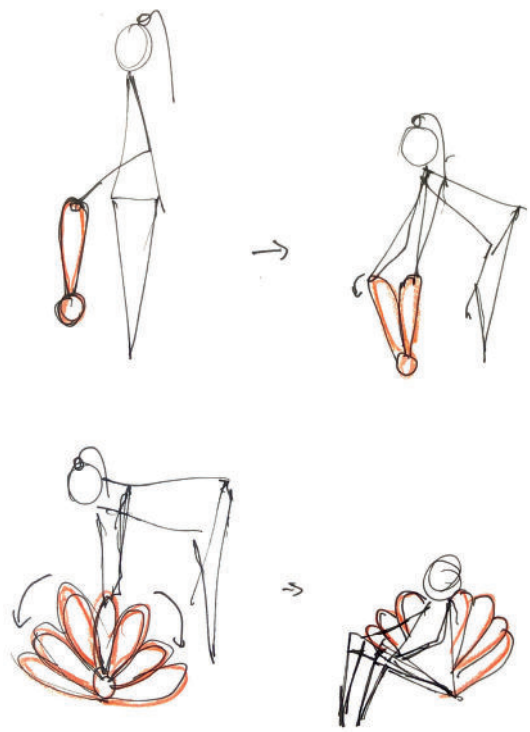
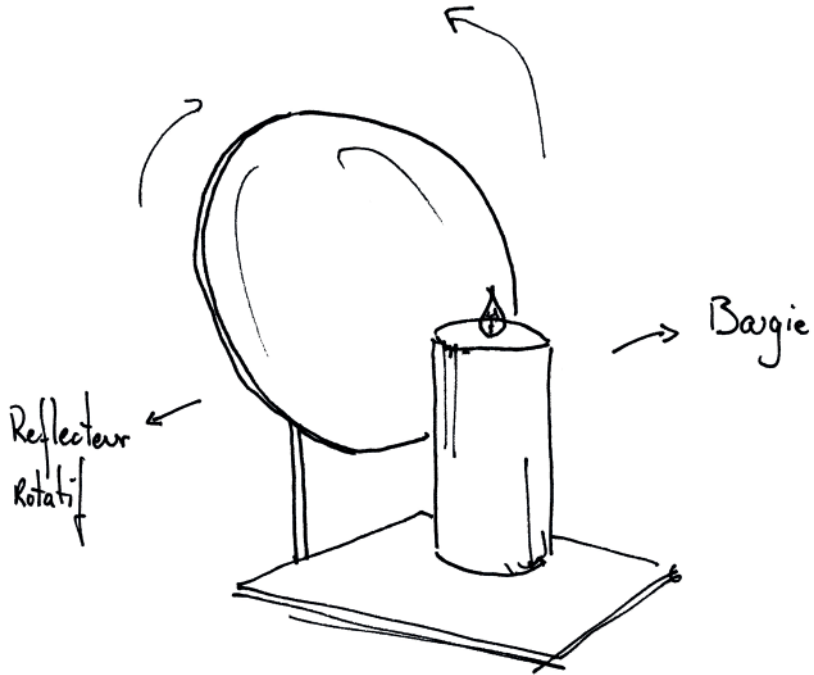

Recherches

# Scénario d'usage

- 1 Nour rentre du travail et allume sa lampe.

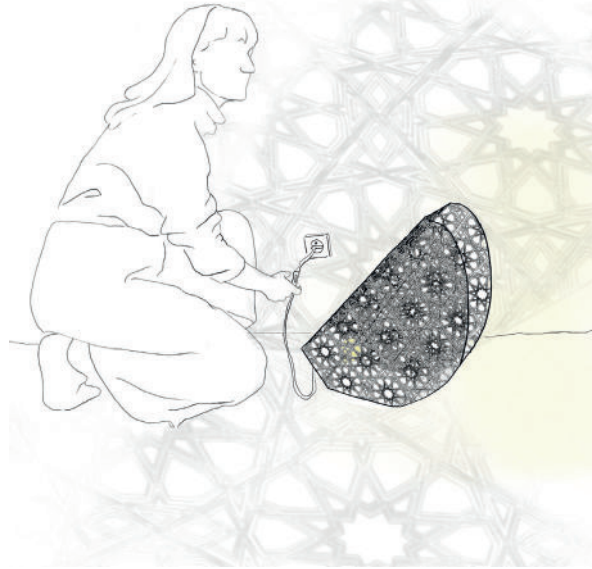

- 2 Il est 18h, l'électricité est coupée, Nour se retrouve dans le noir.



- 3 Elle range alors la lampe pour la remplacer par un bougeoir et l'allume.

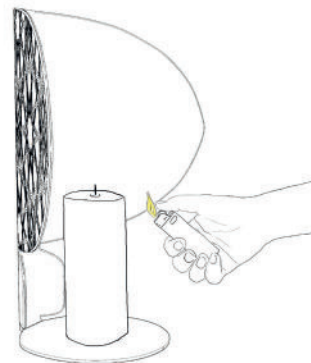
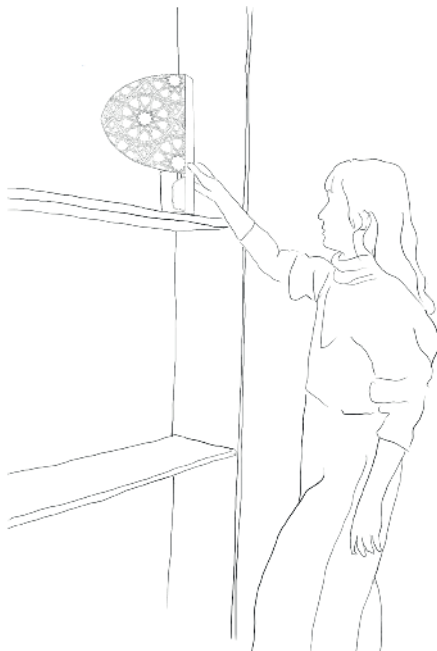



# Reflect & Diffuse

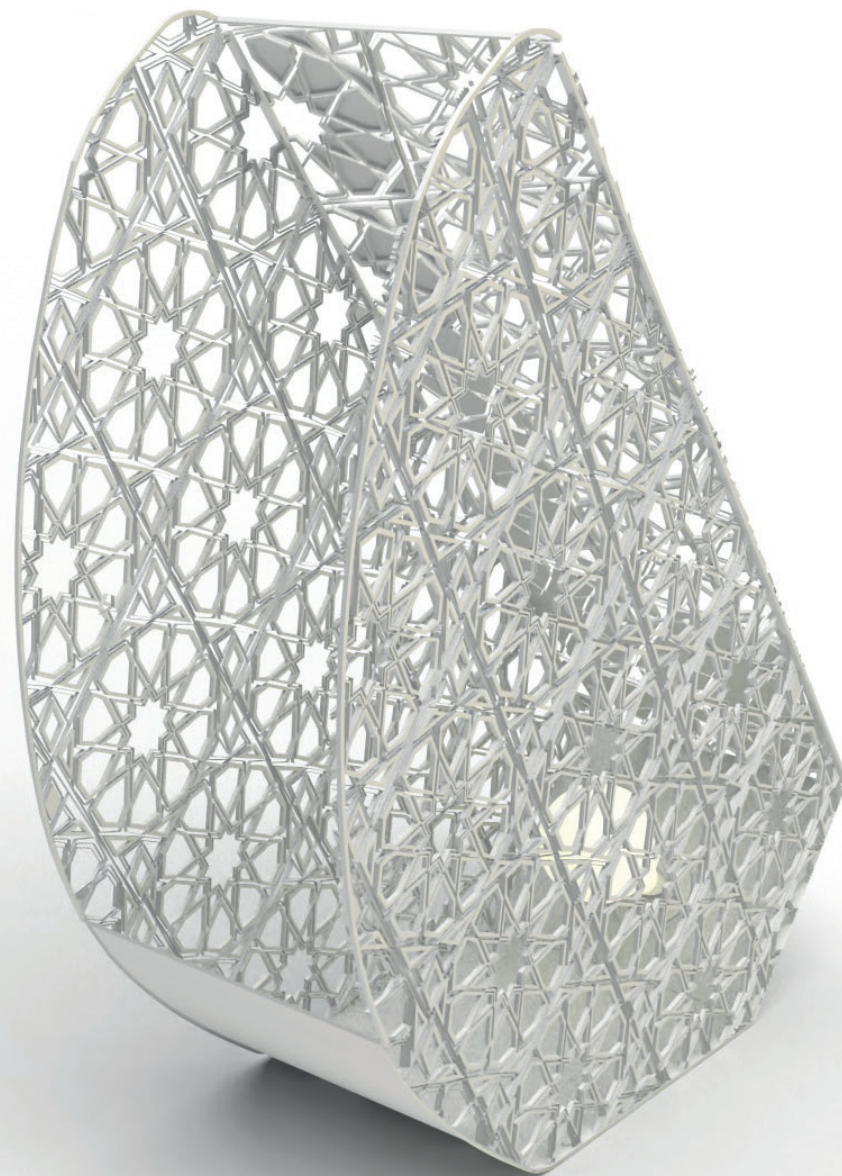

# Mise en situation



# Documents techniques du bougeoir

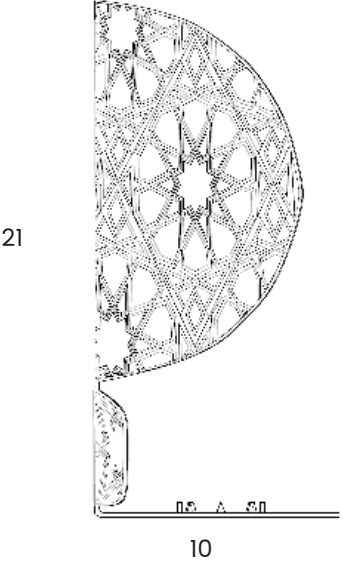

Vue de gauche

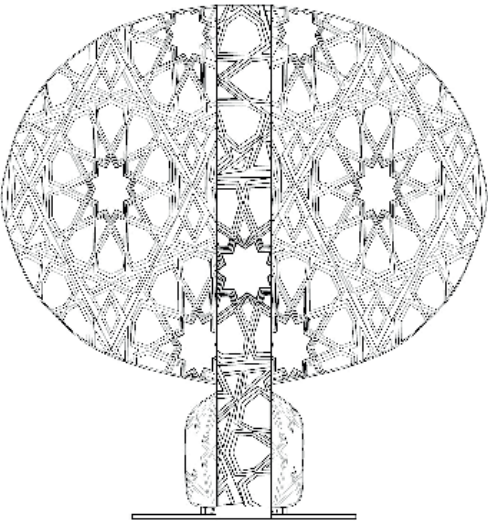

Vue de derrière

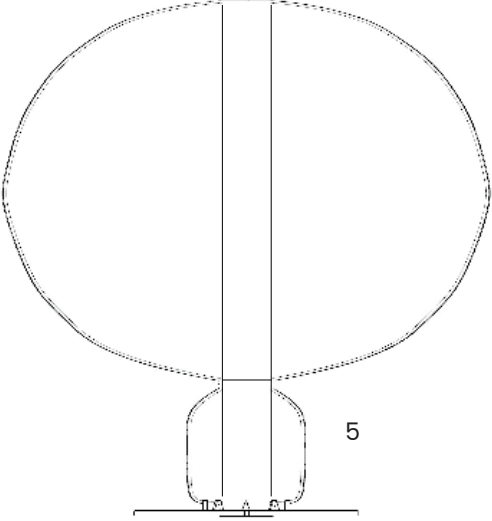

Vue de face

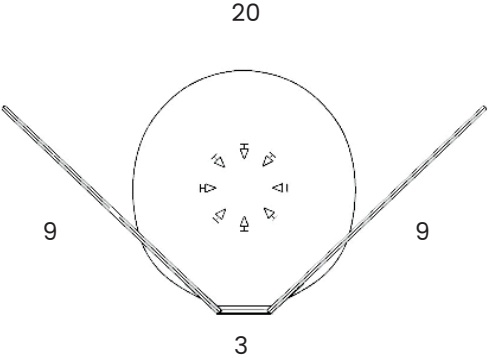

Vue de dessus

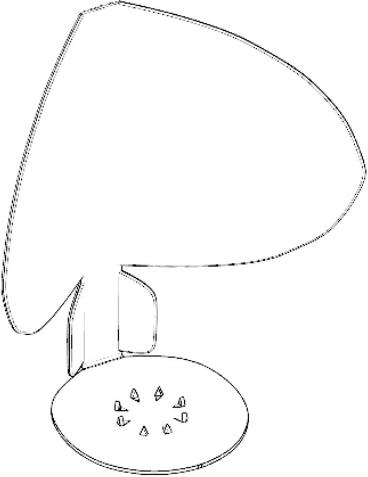

Vue isométrique

# Documents techniques de la lampe

Vue isométrique

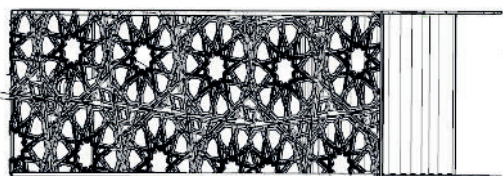
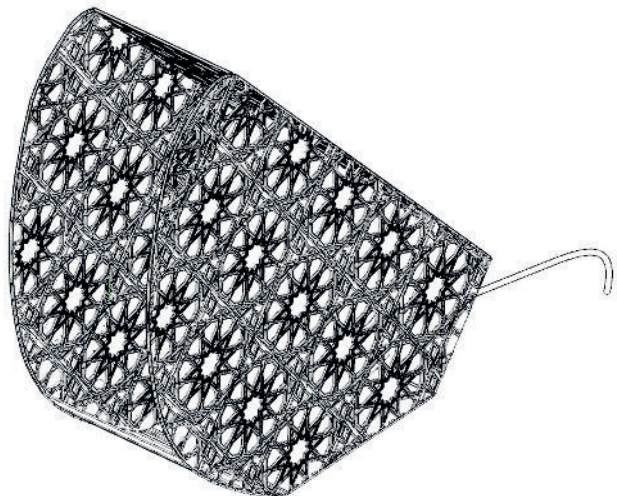

40

Vue de dessus

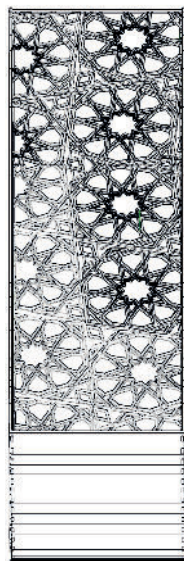

10

Vue de derrière

50

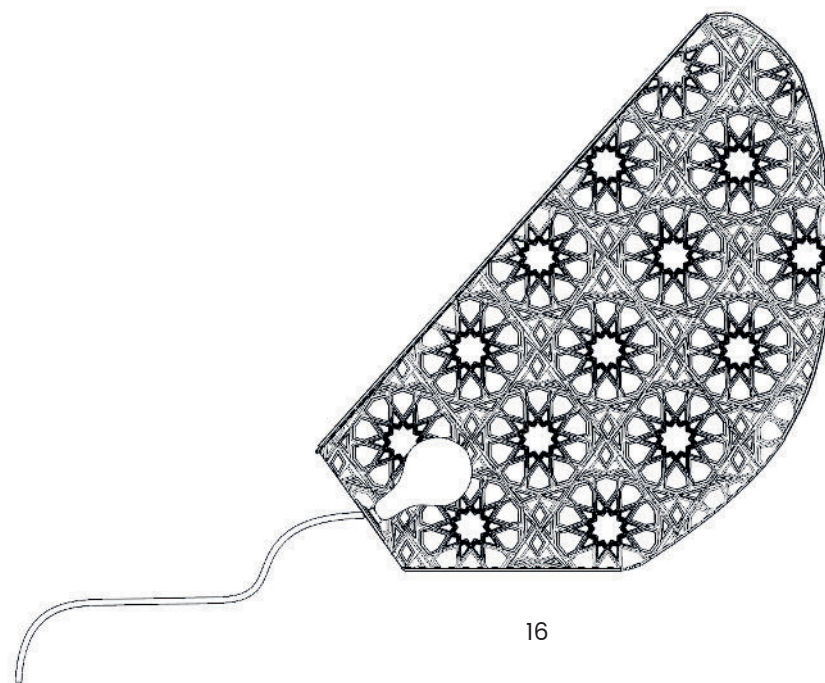

16

Coupe - Vue de gauche

# Production



Découpe

Technique

Assemblage

Collaboration

Gravure

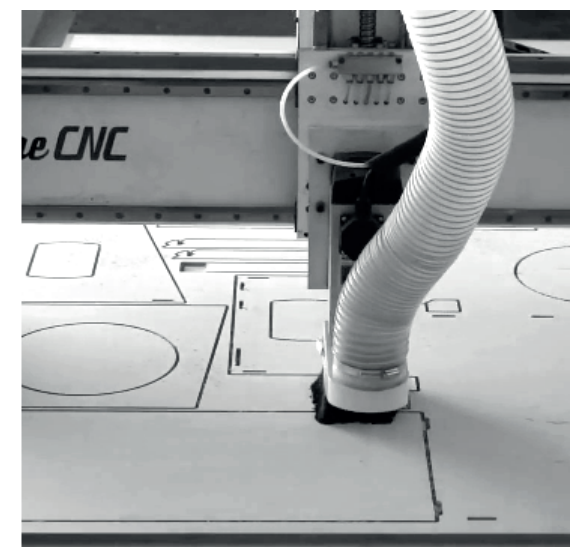
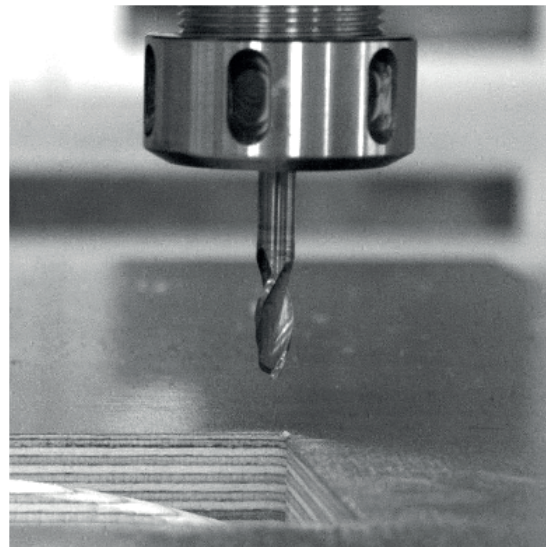

# pazo

Beyrouth, je vous écris de Toulon



# Intentions

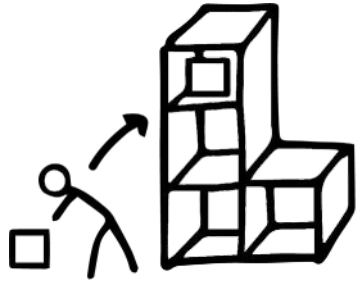

## Ranger

Protéger  
Entreposer  
Accrocher ses affaires

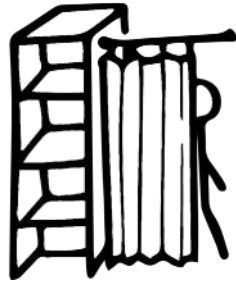

## Cacher

S'habiller  
S'isoler visuellement



## Dormir

Isoler  
le matelas du sol

# Modules

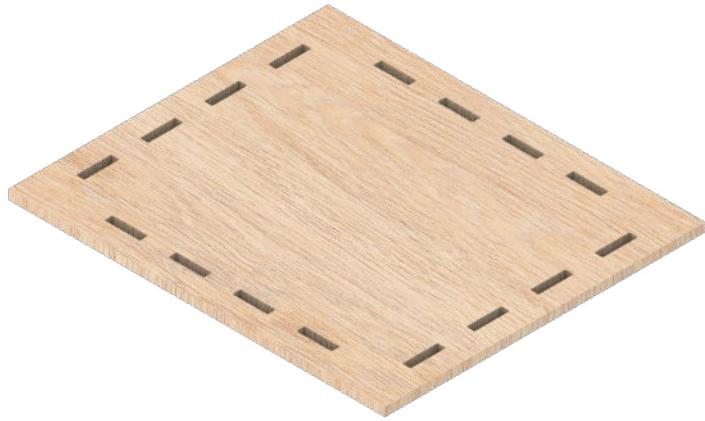

**Panneau horizontal**

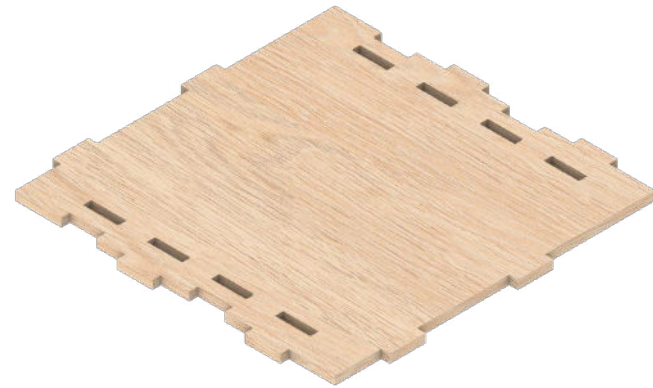

**Panneau vertical**



# Scénario usages

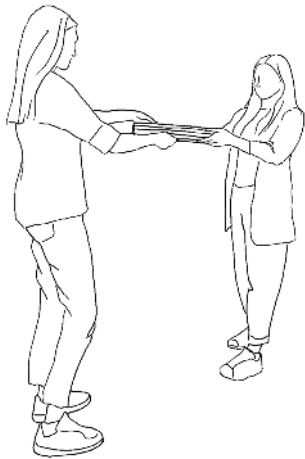

**1. donation**

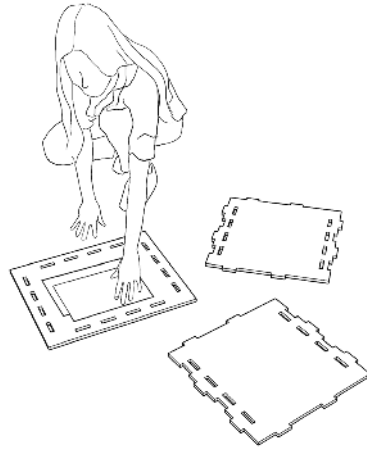

**2. notice**

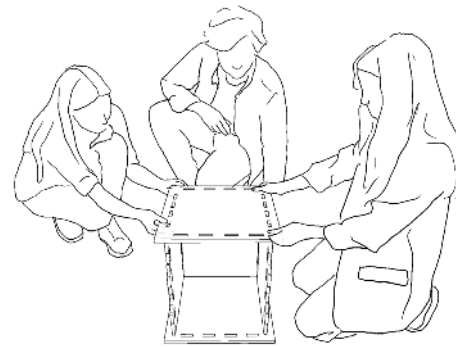

**3. montage**

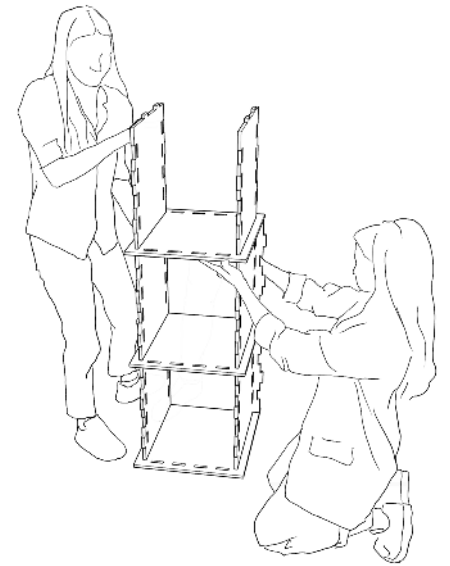

# Objets



**Rangements**

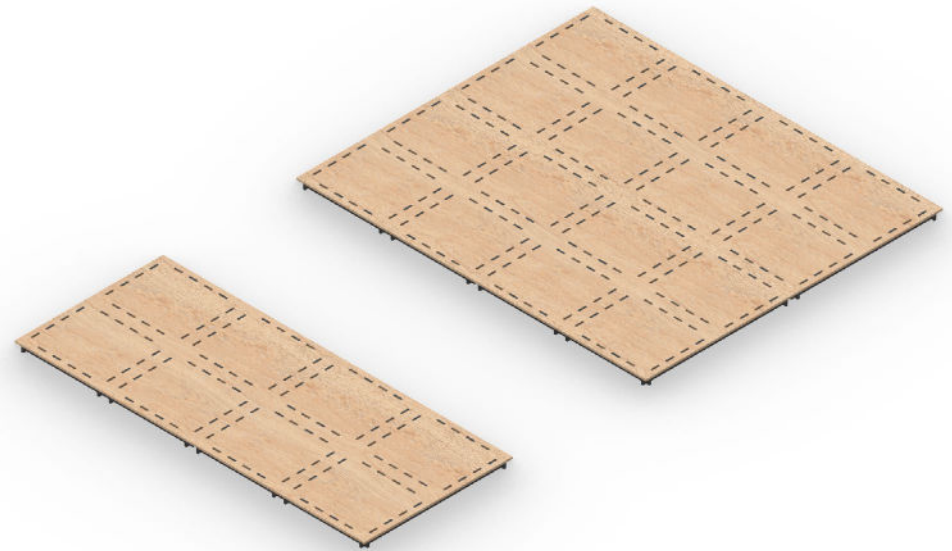

**Futon**

# Objets

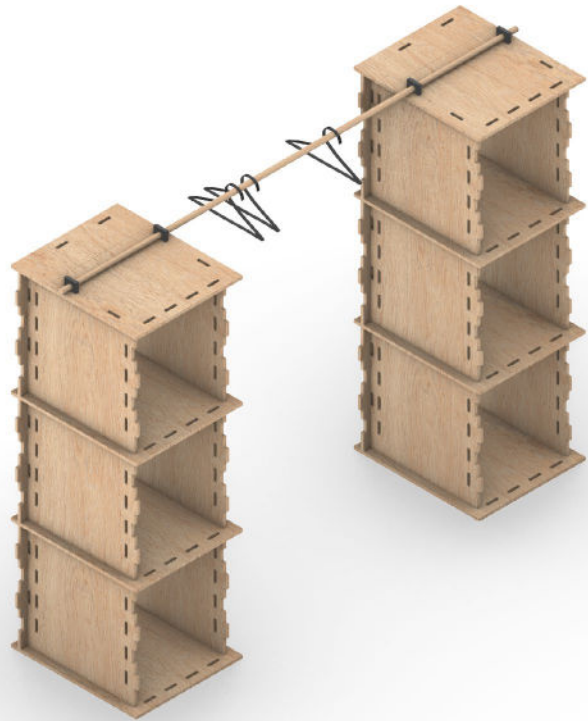

Rangements

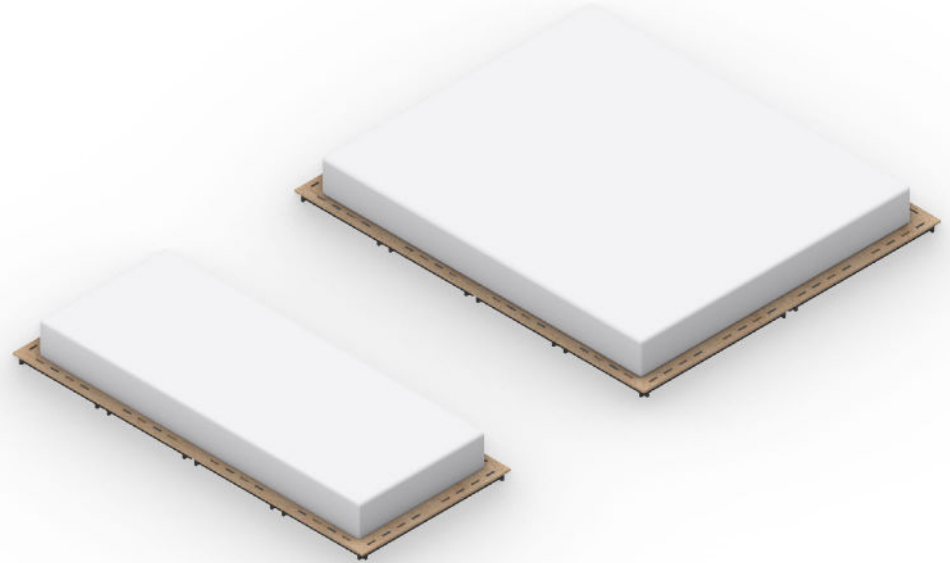

Futon

# Combinaisons

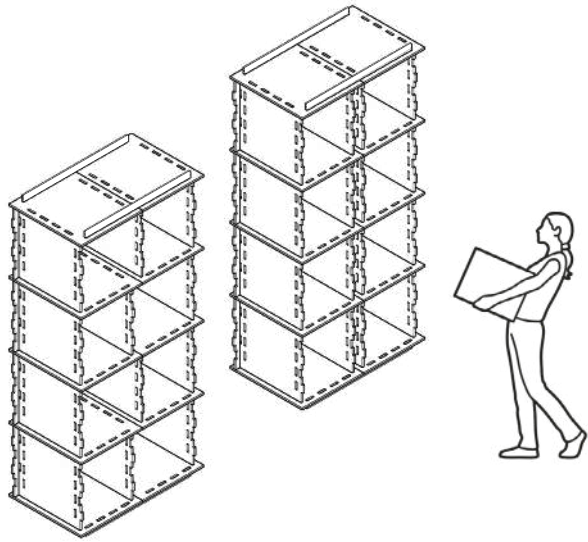

**N.1 colonne**

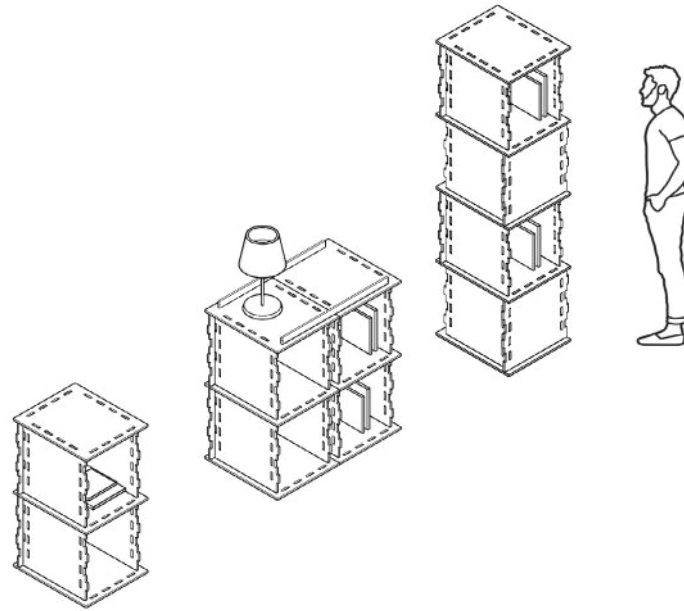

**N.2 commode**

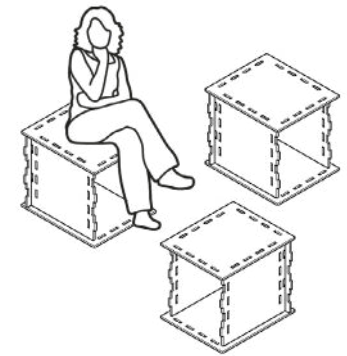

**N.3 assise**

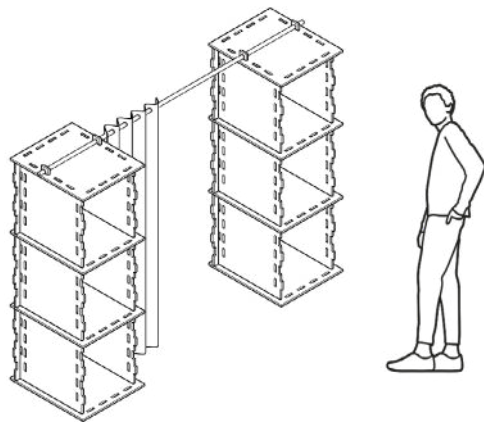

**N.4 cloison**

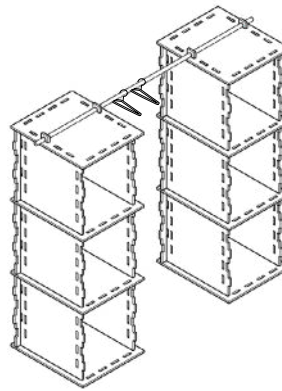

**N.4 penderie**

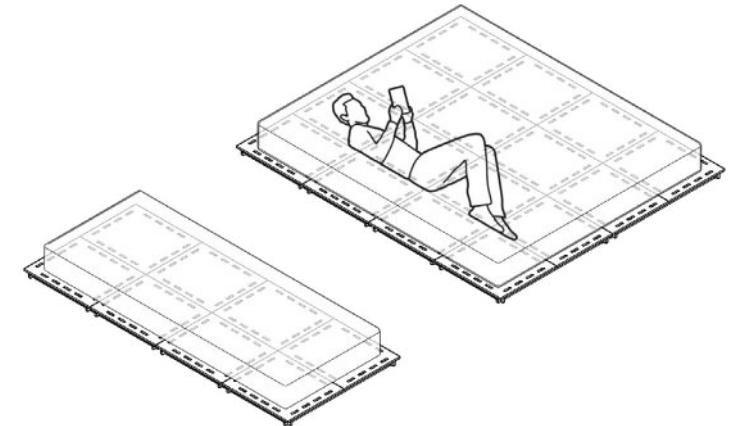

**N.4 futon**

# Dessins techniques

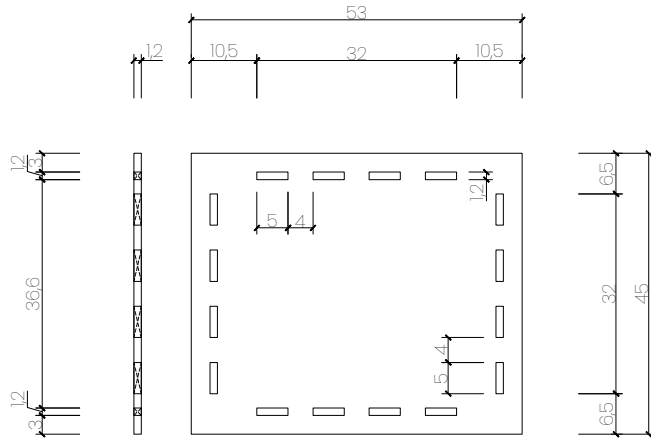

**Panneau 1**

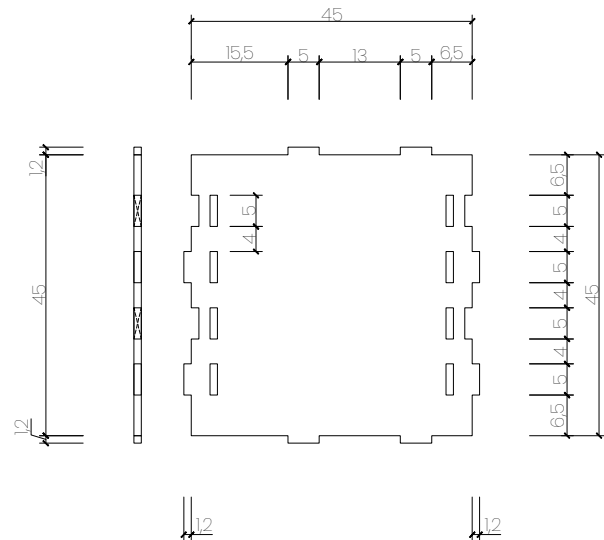

**Panneau 2**

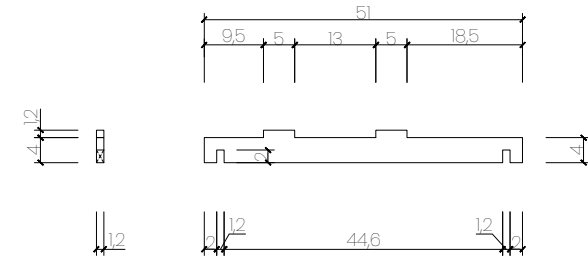

**Latte 1**

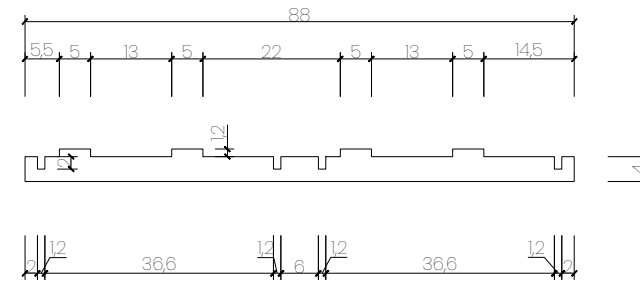

**Latte 2**

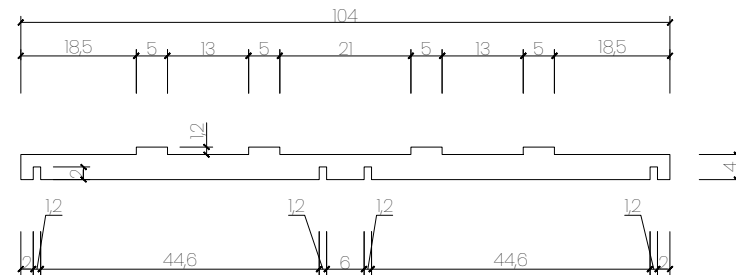

**Latte 3**

# Production



Panneaux contreplaqués  
peuplier / 12 mm

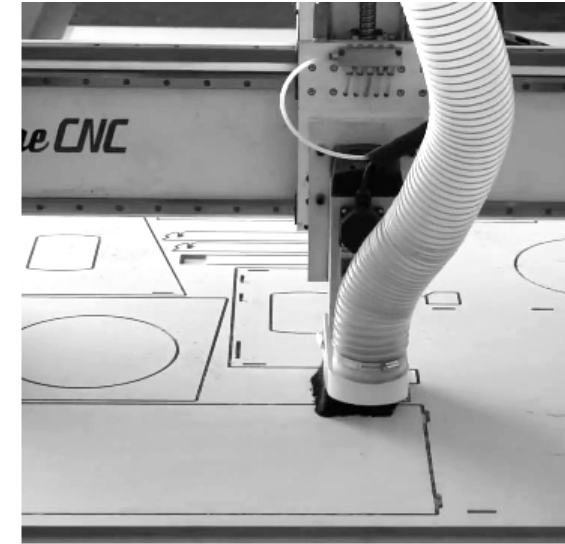

Découpe : fraiseuse numérique  
C.N.C.

**Découpe**

**Technique**

**Assemblage**

**Collaboration**

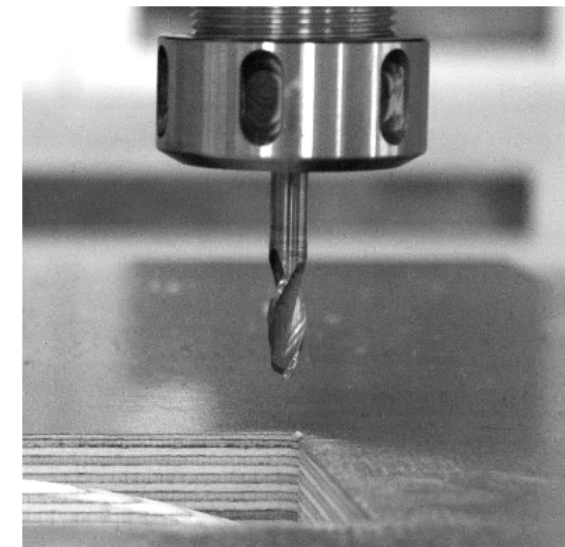

# Dukouh

Beyrouth, je vous écris de Toulon

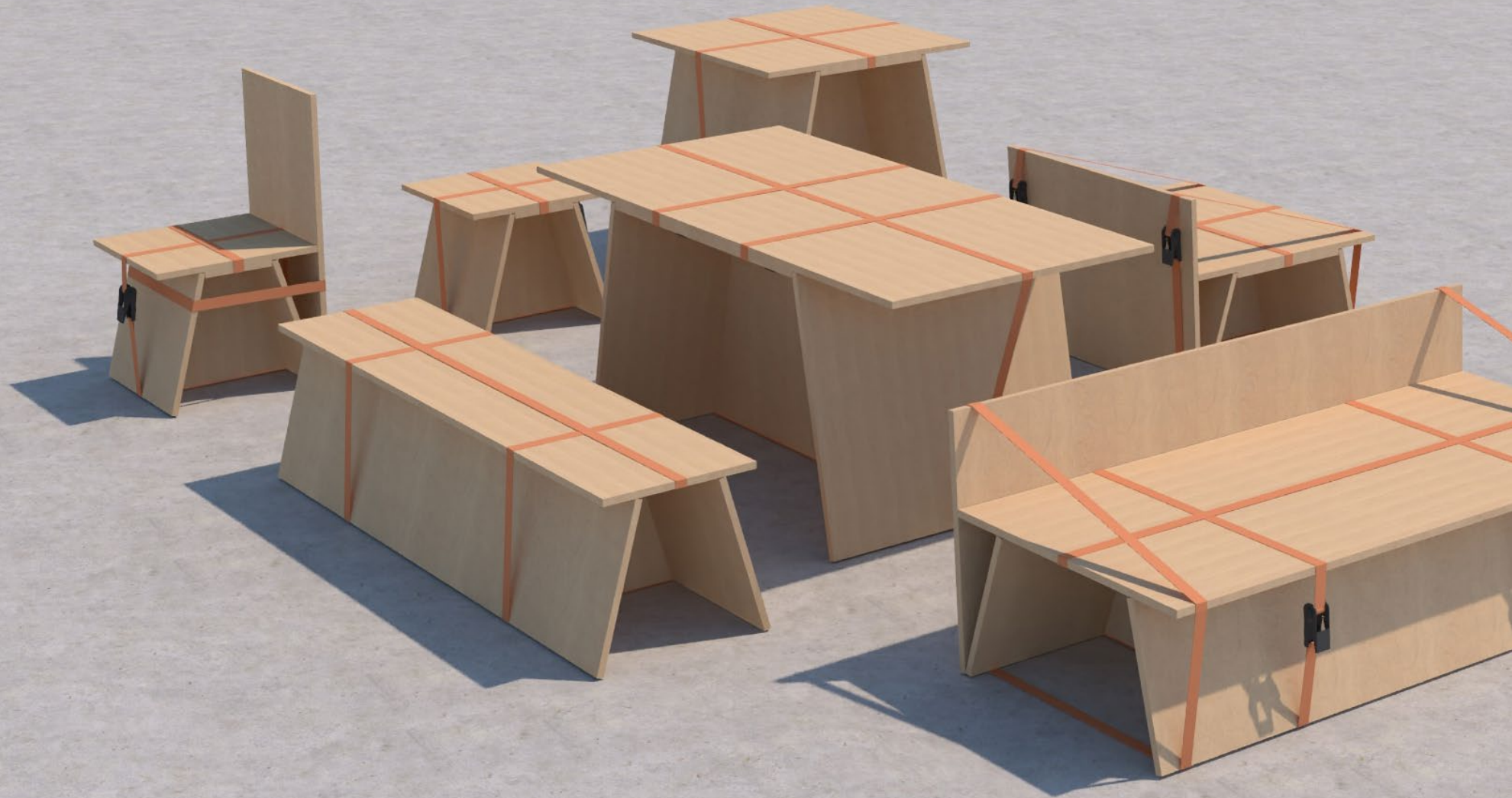

# Intentions

## Enjeux

Les ambitions de ce projet sont différentes et presque opposées. Il s'agit de **répondre à une situation d'urgence** en remeublant les intérieurs d'une ville en situation de crise. Il s'agit aussi de donner une **impression de stabilité** au Beyrouthins et de leur offrir un **confort** qui leur permet de **se projeter dans l'avenir**. C'est cette envie contradictoire, à l'image de la ville de Beyrouth, qui a fait naître notre projet.

## Projet

Le projet s'axe autour d'une gamme de mobilier pour le salon où **l'utilisateur joue un rôle dans l'approvisionnement en matériaux et dans l'assemblage**. Cela permet aux habitants de choisir leurs matériaux, de **s'investir dans la construction** de leur intérieur et de rendre l'assemblage accessible à tous. Le projet a aussi pour but de pouvoir être amélioré au fil du temps par son propriétaire grâce à des éléments extérieurs qui lui sont propres. L'objet est **propice au détournement** pour qu'il puisse **évoluer** au cours de la vie d'un beyrouthin, qu'il puisse y **ajouter du confort et se l'approprier**.



# Recherches

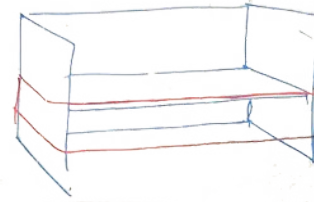
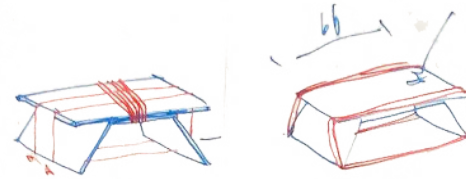
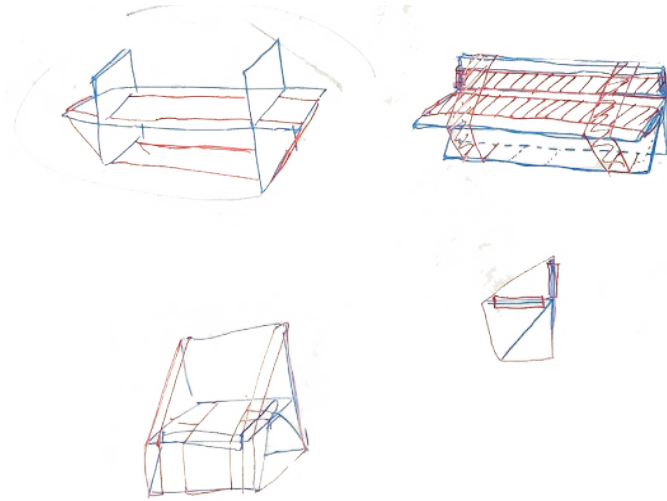

## ① ASSEMBLAGE



## ② ENVELOPPE

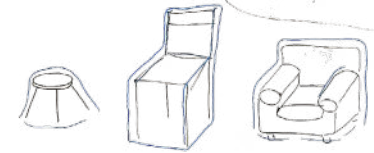

## ③ EXPERIMENTATIONS MATIÈRES

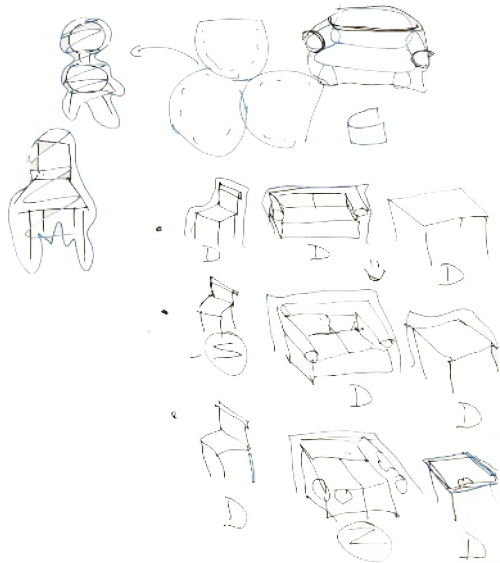
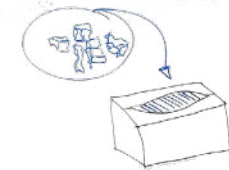

## TABLE A MANGER:

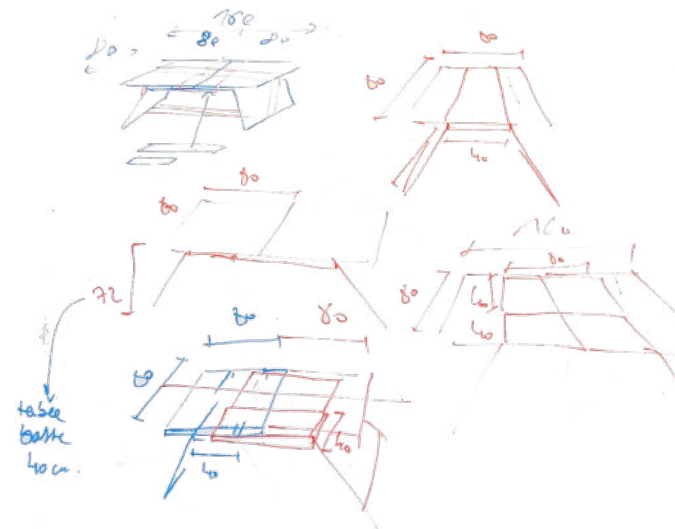

# Tabouret

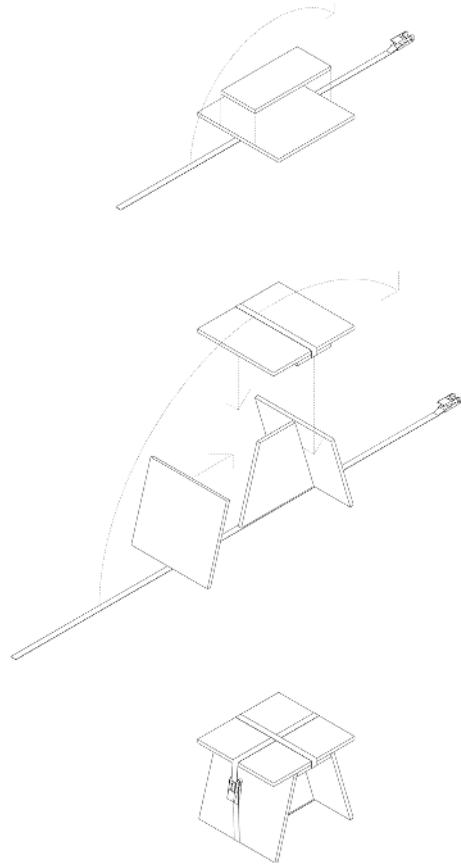

# Banc

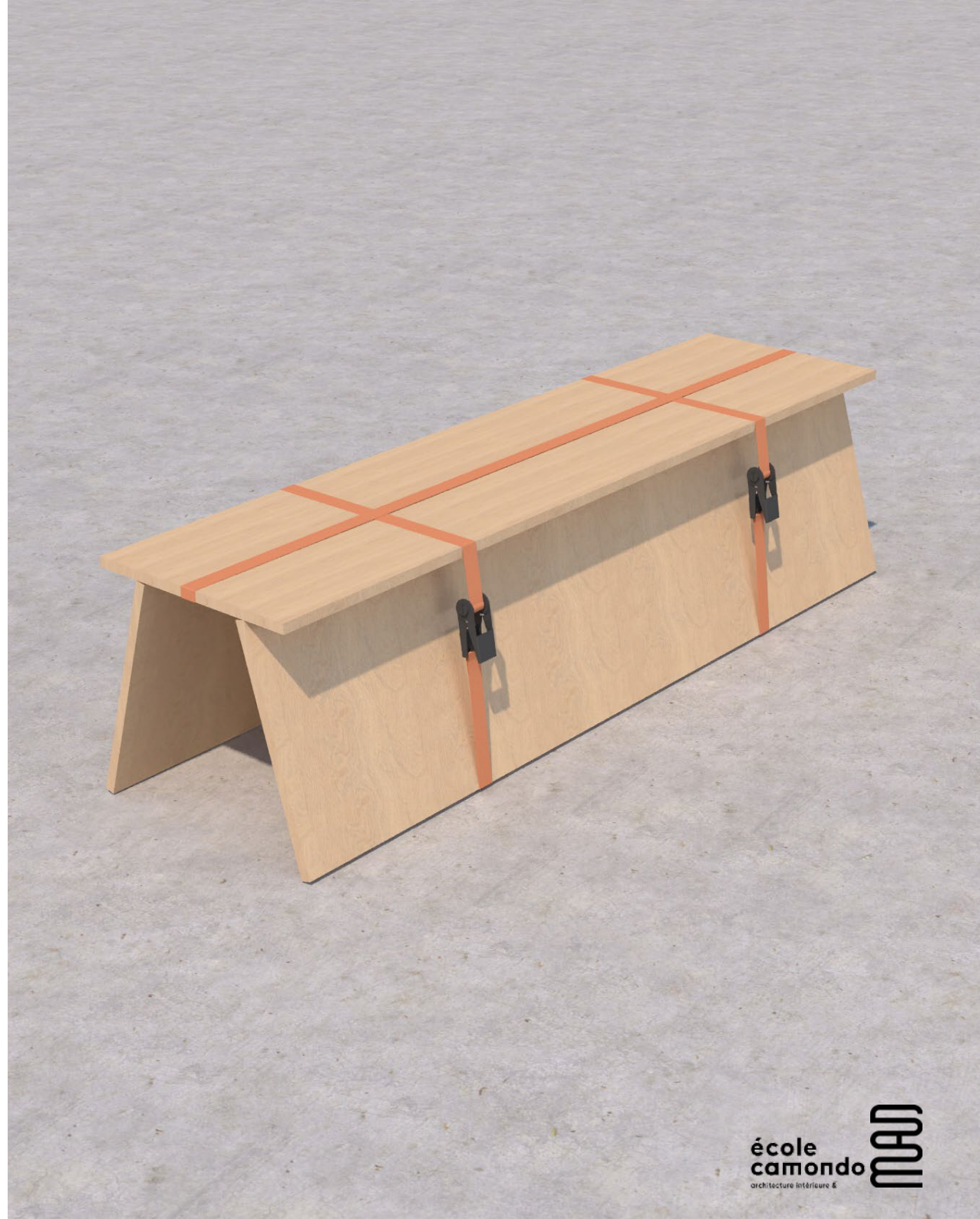
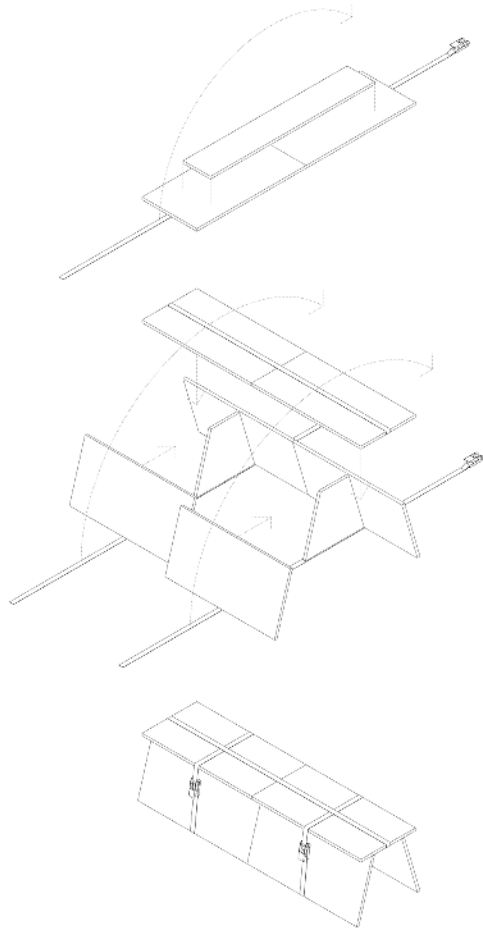

# Chaise

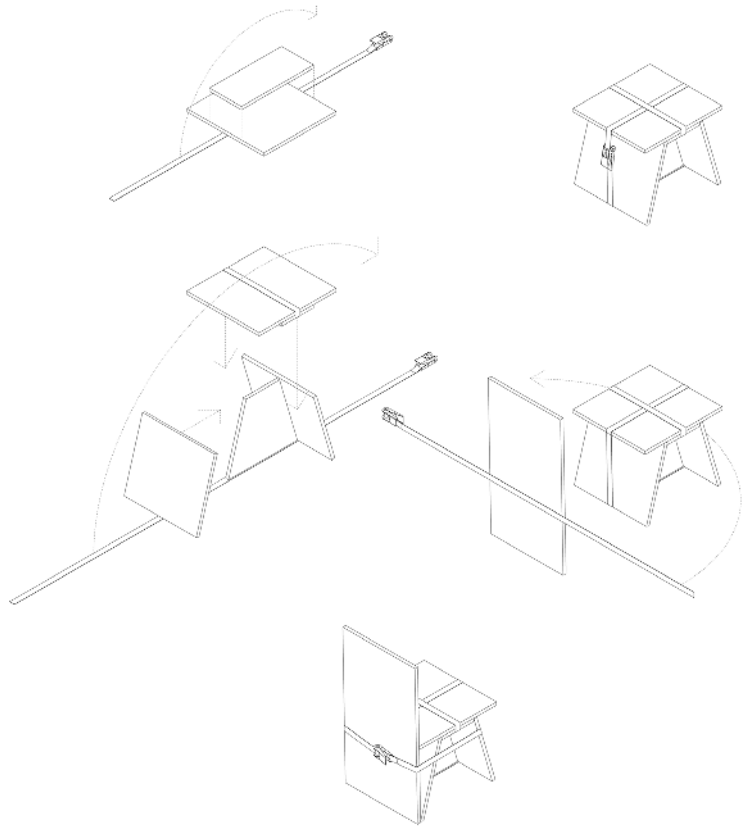

# Fauteuil

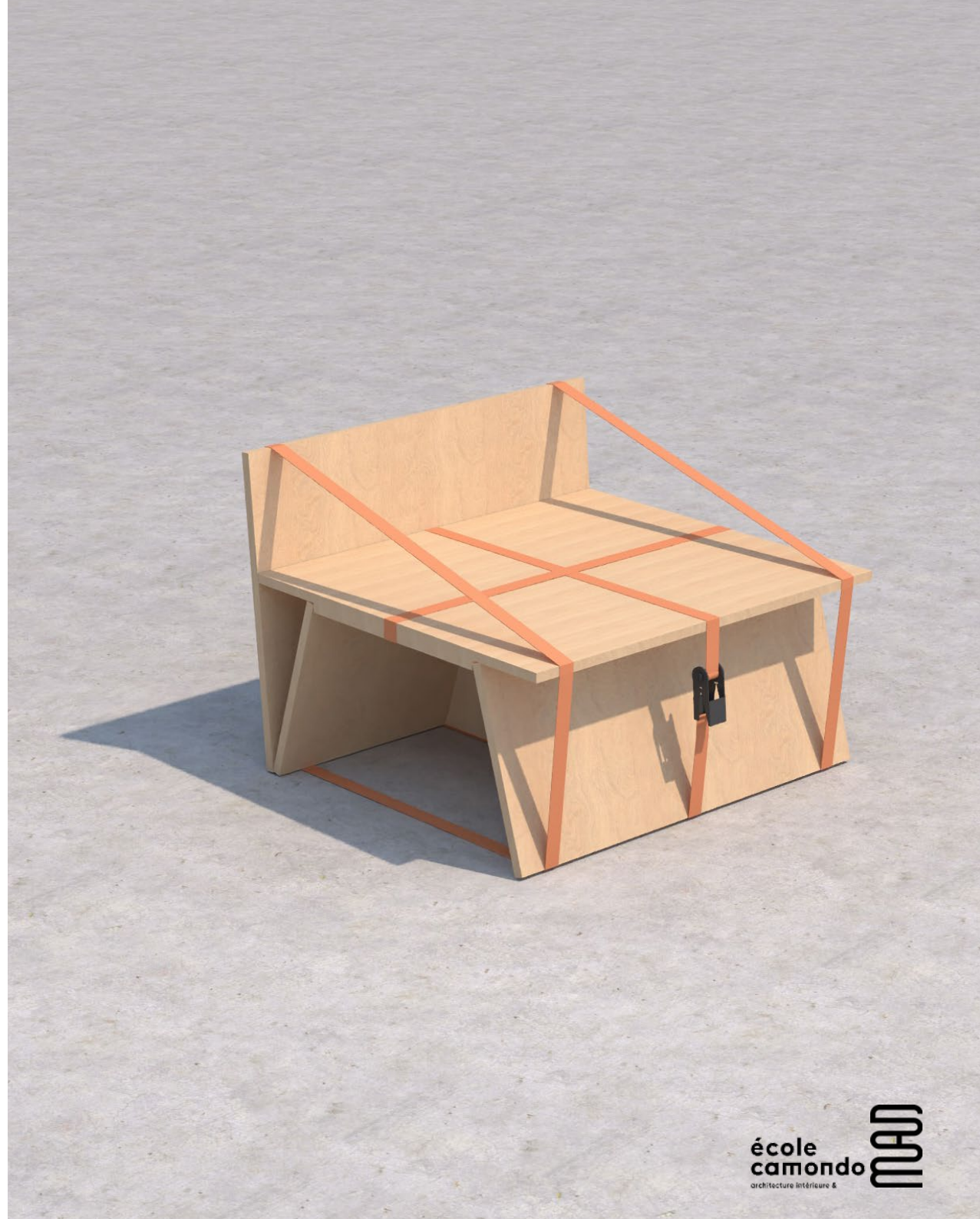
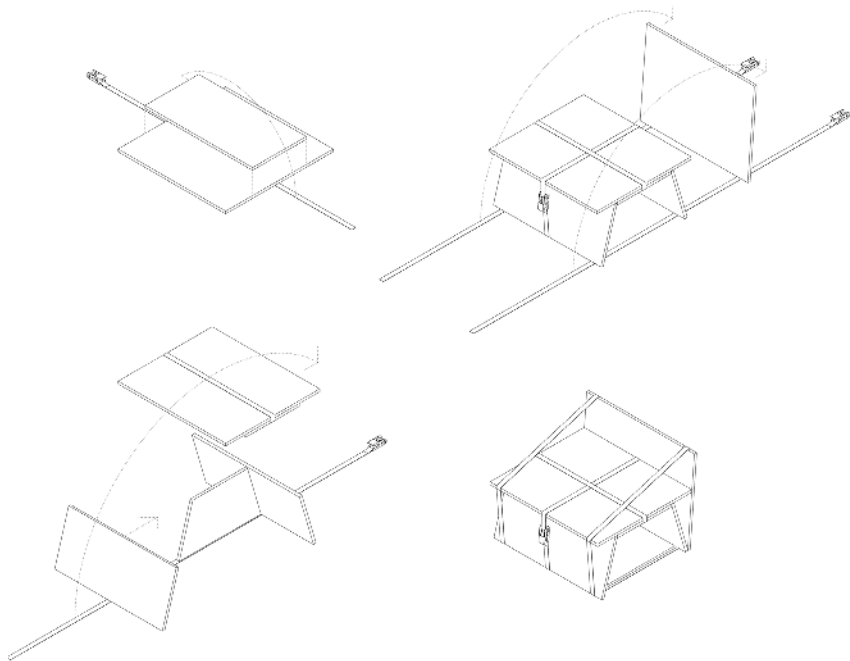

# Canapé

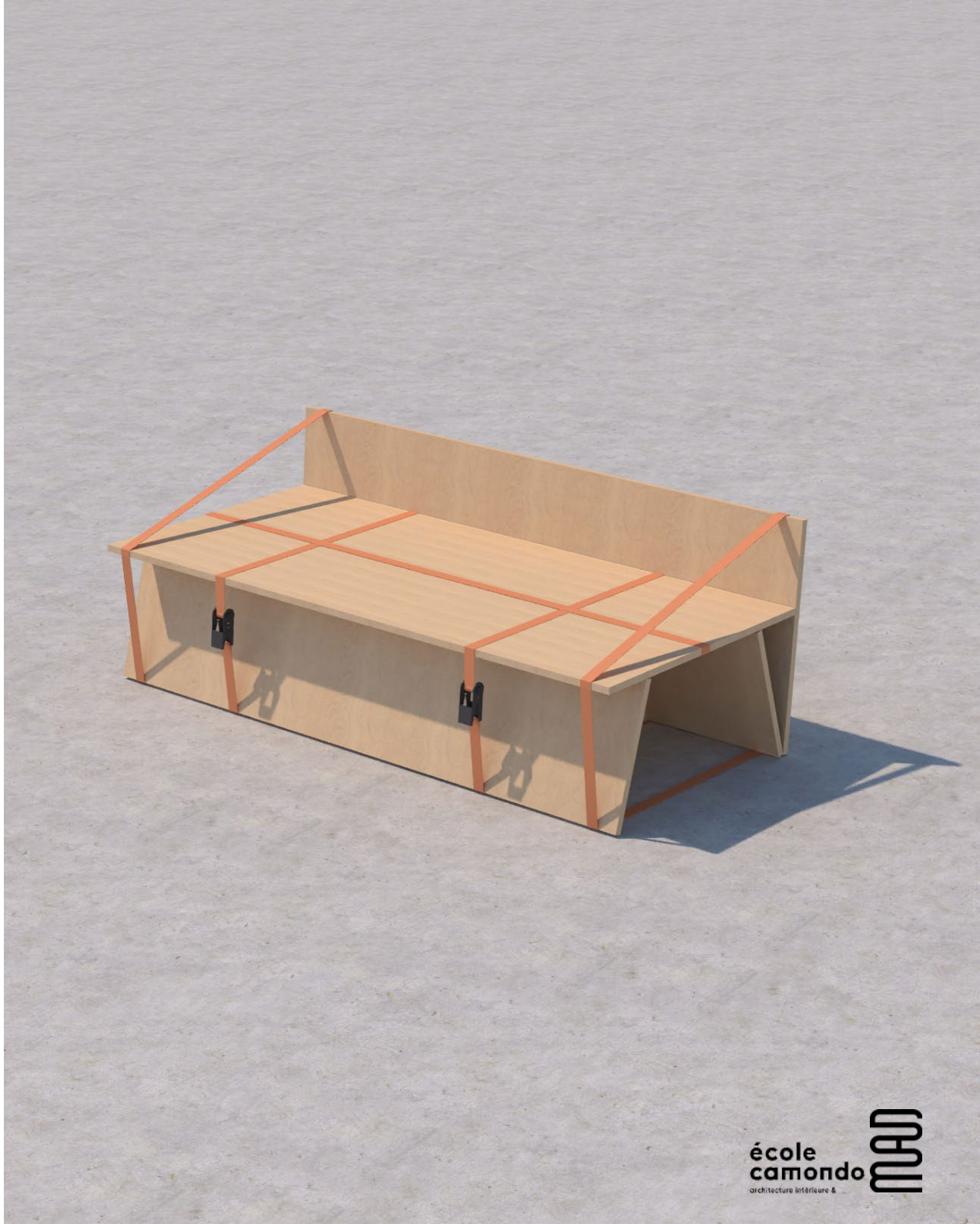
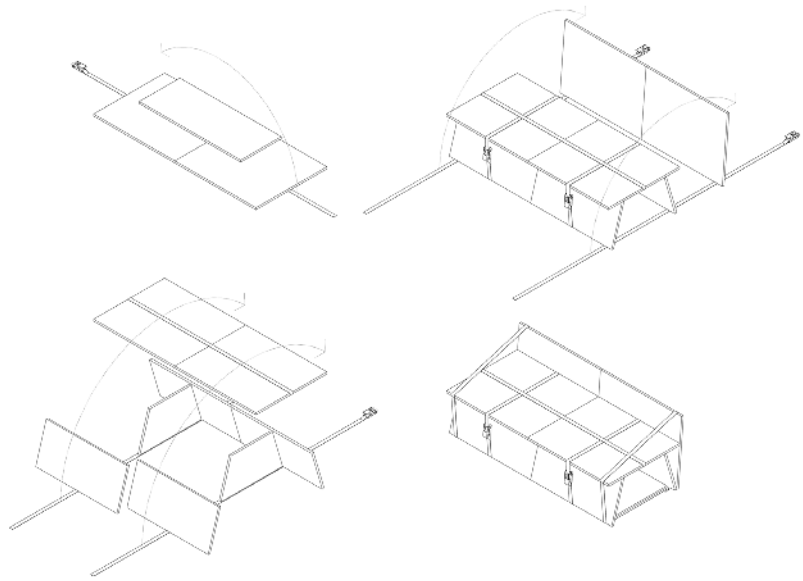

# Grande table

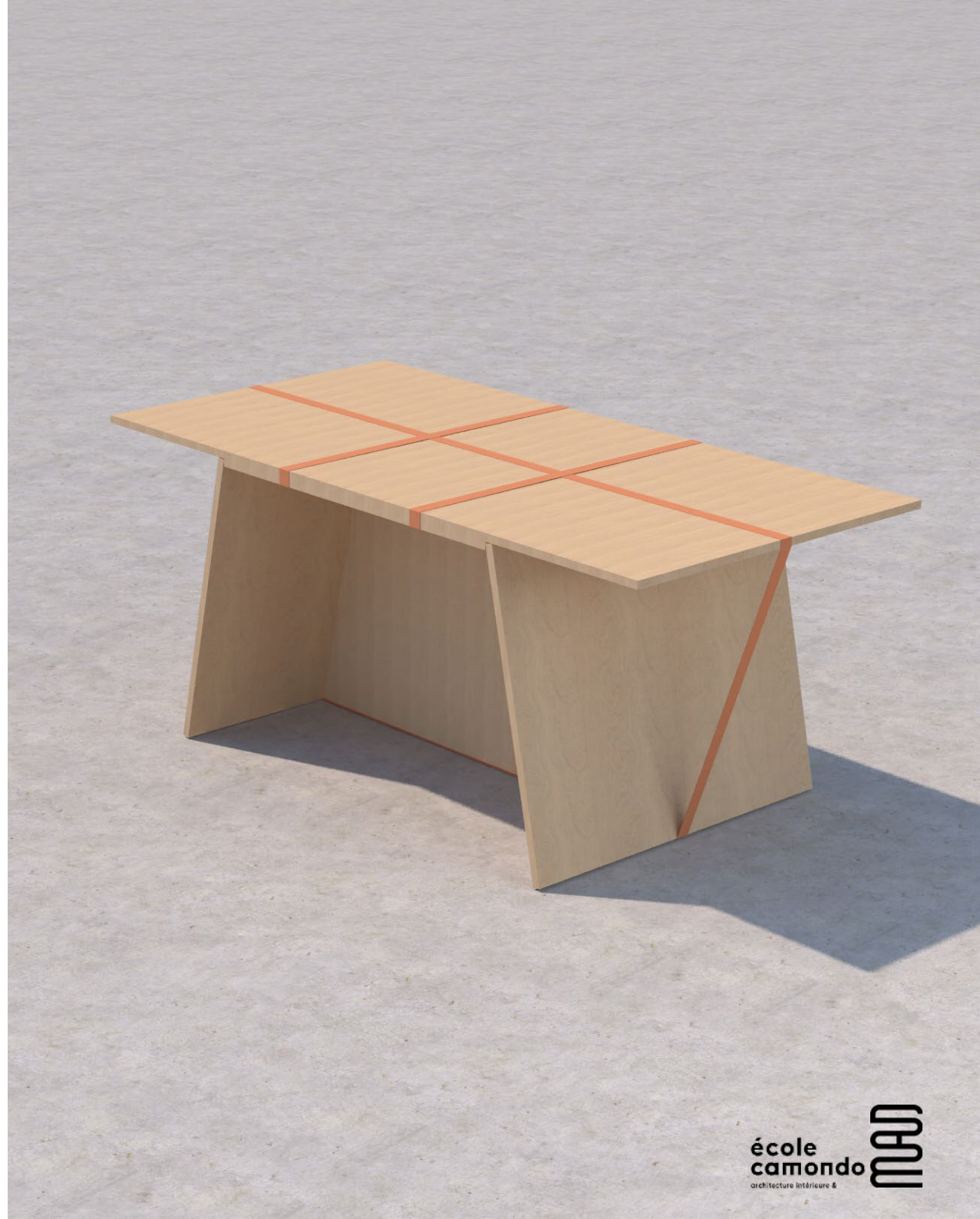
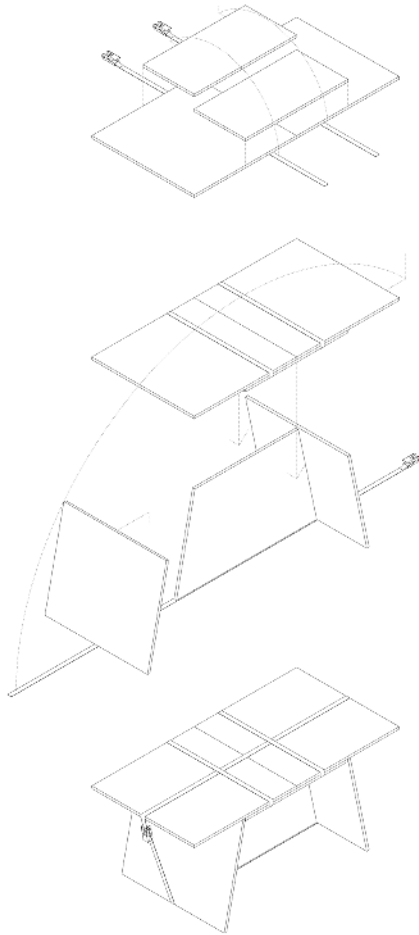

# Petite table

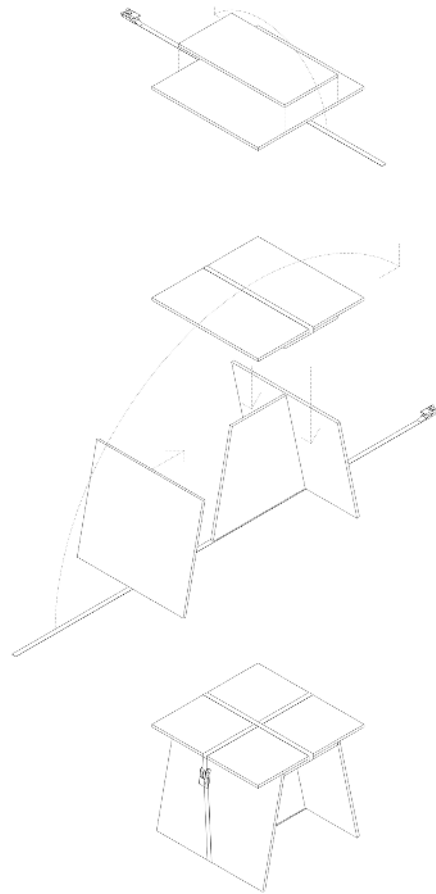



# Scénario usages

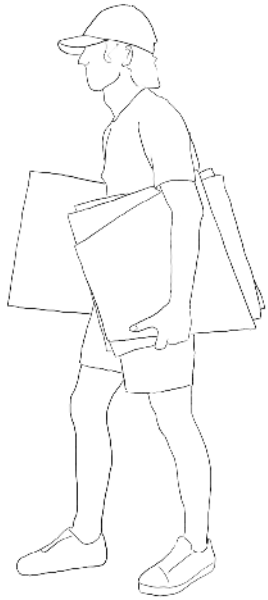

## Récupérer

Marc récupère ses planches venant:

- d'une ONG
- de chez lui
- d'une boutique

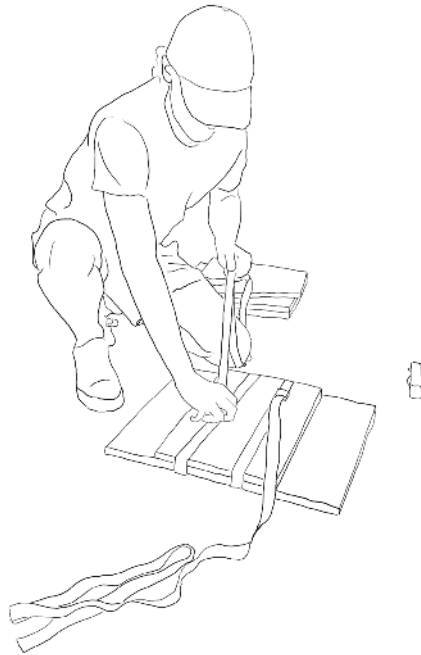

## Assembler

Il suit la notice et assemble les différentes planches ensemble

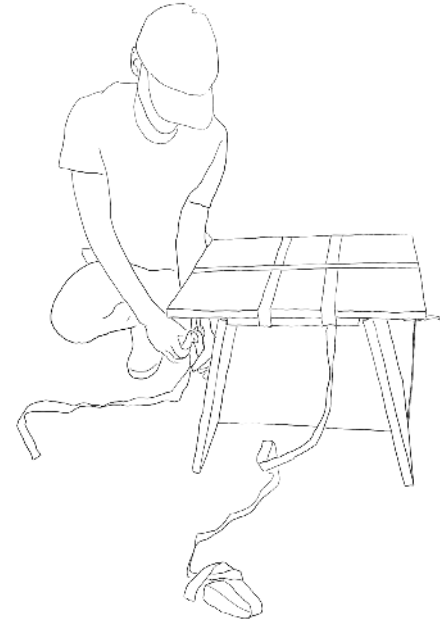

## Serrer

Il serre ensuite chaque sangle au maximum pour assurer la stabilité

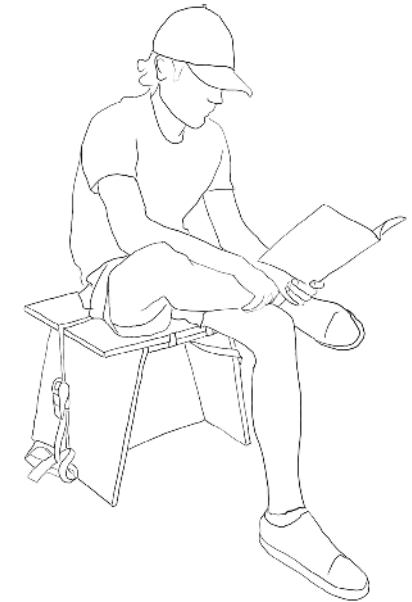

## S'approprier

Marc utilise son meuble en fonction de ses besoins

# Personnalisation

Vues spéculatives du projet approprié  
par un Beyrouthin



# Prototype

Prototypage du tabouret et essai d'une pièce d'assemblage en chute de textile

